

March 28, 2023

Mr. Joshua Middleton
Town Engineer
400 South Main Street
Blacksburg, Virginia 24060
Phone: (540) 443-1353

Reference: **Northside Subdivision** – Traffic Impact Analysis (TIA)
Town of Blacksburg, Virginia

Dear Mr. Middleton,

CC & B Development, LLC is proposing to construct a residential development north of Givens Lane and west of N Main Street. The development plan includes 51 single family units with site access via interconnectivity with Progress Street, Carroll Drive, and Primrose Drive. If approved, the proposed neighborhood is expected to be built-out by 2027. Ramey Kemp & Associates, Inc. (RKA) has performed this Traffic Impact Analysis (TIA) based on discussions with the Town of Blacksburg (the Town). Figure 1 shows the site location and study intersections, and Figure 2 shows the preliminary site plan.

Existing Roadway Conditions

Main Street is a two-lane Minor Arterial with an average daily traffic (ADT) volume of approximately 6,500 vehicles per day (vpd) and a posted speed limit of 35 miles per hour (mph) in the vicinity of the site.

Givens Lane is a local roadway with an ADT volume of approximately 1,500 vpd and a posted speed limit of 25 mph in the vicinity of the site.

Progress Street is a local roadway with an ADT volume of approximately 1,100 vpd and a posted speed limit of 25 mph in the vicinity of the site.

Carroll Drive and Countryside Court are both local roadways with no published ADT volumes. Based on 2022 existing traffic counts and assuming the PM volumes are 10% of the daily traffic volumes, ADTs are estimated at 880 vpd and 580 vpd, respectively.

Figure 3 shows the existing roadway laneage at the study intersection.

Existing Traffic Volumes

AM peak hour (7:00 to 9:00 AM) and PM peak hour (4:00 to 6:00 PM) traffic volumes were derived from turning movement counts conducted by Burns Services, Inc. at the following intersections:

- N Main Street and Countryside Court – during the week of October 17th
- N Main Street and Givens Lane/Mountain Breeze Drive – during the week of April 11th
- Givens Lane and Carroll Drive – during the week of October 17th
- Givens Lane and Progress Street – during the week of October 17th

The traffic count data is enclosed, and the existing 2022 volumes are shown in Figure 4.

Approved Developments

Based on discussions with the Town, the following approved developments were included in this TIA:

- Whipple Drive Townhomes
- Hayes Colony
- The Summit

Background Traffic Growth

Based on discussions with the Town, the 2022 peak hour traffic volumes were grown by an annual rate of 2.5% per year for five years to estimate the 2027 projected peak hour traffic volumes which are shown in Figure 5. Refer to Figure 6 for the adjacent development trips. The 2027 no-build traffic volumes were determined by adding the adjacent development trips to the projected peak hour traffic volumes. Refer to Figure 7 for an illustration of the 2027 no-build peak hour traffic volumes at the study intersections.

Trip Generation

Table 1 shows the trip generation potential of the proposed community based on the Institute of Transportation Engineers (ITE) *Trip Generation Manual – 11th Edition*.

Table 1: ITE Trip Generation – Weekday – 11th Edition

Land Use (ITE Land Use Code)	Size	Weekday Daily Traffic (vpd)		AM Peak Hour (vph)		PM Peak Hour (vph)	
		Enter	Exit	Enter	Exit	Enter	Exit
Single Family Detached (210)	51 Units	272	272	10	30	33	20

Based on information contained within the Trip Generation Manual, the development could be expected to generate approximately 544 trips on a typical weekday with 40 trips (10 entering and 30 exiting) generated during the AM peak hour and 53 trips (33 entering and 20 exiting) generated during the PM peak hour. It should be noted that due to proximity to campus and existing near-by bus stops, it is expected that a percentage of traffic would utilize alternate modes of transportation (i.e. Blacksburg Transit), however, to provide a conservative approach, no reductions were applied.

Site Trip Distribution

The following site trip distribution was applied based on a review of the existing traffic volumes, the adjacent roadway network, and engineering judgement:

- 10% to / from the north on N Main Street
- 60% to / from the south on N Main Street
- 15% to / from the west on Givens Lane
- 15% to / from the south on Progress Street

Figure 8 shows the site trip distribution, Figure 9 shows the site trip assignment, and Figure 10 shows the build 2027 peak hour traffic volumes.



VDOT Turn Lane Warrant Analysis

The projected AM and PM peak hour traffic volumes at the intersections of N Main Street/Countryside Court and Givens Lane/Carroll Drive were compared to the turn lane warrants in the Virginia Department of Transportation (VDOT) *Access Management Design Standards for Entrances and Intersections*. Based on a review of the turn lane warrants, a northbound left turn lane is warranted on Main Street at both Countryside Court and Givens Lane under no-build conditions (without the construction of the proposed development). Because a turn lane is warranted without the proposed development, no turn lane was included as part of the capacity analysis.

Traffic Capacity Analysis

Traffic capacity analysis for the study intersections was performed using Synchro 10, which is a comprehensive software package that allows the user to model signalized and unsignalized intersections to determine levels-of-service based on the thresholds specified in the Highway Capacity Manual (HCM) – 6th Edition. The software package SIDRA INTERSECTION 9 was utilized for all roundabout analysis. For roundabout intersections, Sidra provides LOS calculations for all approaches and an overall resulting LOS. Synchro capacity analysis results for unsignalized intersections do not provide an overall LOS, but rather a LOS for movements approaches that have a conflicting movement.

Per coordination with the Town, all analysis scenarios utilized the actual heavy vehicle percentages (HVP) by movement that were collected in the turning movement counts. Additionally, existing analysis scenarios utilized the calculated peak hour factor (PHF) from the collected traffic counts for the overall intersection. For future analysis scenarios, a minimum PHF of 0.92 and the calculated PHF from the collected traffic counts was utilized. Existing pedestrian volumes from the collected traffic counts were analyzed within the analysis scenarios for all traffic conditions.

Table 2 summarizes the capacity analysis results for the existing unsignalized intersection of N Main Street at Countryside Court. The Synchro outputs are enclosed for reference.

Table 2: Level-of-Service Summary for N Main Street at Countryside Court

CONDITION	LANE GROUP	AM PEAK HOUR				PM PEAK HOUR			
		Lane LOS	Lane Delay (sec)	Lane Queue (ft)	Overall LOS (Delay)	Lane LOS	Lane Delay (sec)	Lane Queue (ft)	Overall LOS (Delay)
Existing (2022) Conditions	EBL/R ¹	B	14	5	N/A ³	B	12	5	N/A ³
	NBL/T ²	A	9	0		A	8	3	
	SBT/R ²	-	-	-		-	-	-	
No-Build (2027) Conditions	EBL/R ¹	B	14	5	N/A ³	B	12	5	N/A ³
	NBL/T ²	A	9	0		A	8	3	
	SBT/R ²	-	-	-		-	-	-	
Build (2027) Conditions	EBL/R ¹	B	14	8	N/A ³	B	13	5	N/A ³
	NBL/T ²	A	9	0		A	8	3	
	SBT/R ²	-	-	-		-	-	-	

1. Level of service for minor approach
2. Level of service for major-street left-turn movement
3. HCM methodology does not provide lane group or overall LOS, delay, and queue lengths for major street through movements or right turns at unsignalized intersections.



Capacity analysis indicates that the minor-street and major-street left-turn movements are expected to operate at LOS B or better during the AM and PM peak hours. Due to acceptable levels of service and minimal impacts from the proposed development, no improvements are recommended by the developer.

Table 3 summarizes the capacity analysis results for the existing unsignalized intersection of N Main Street at Givens Lane/Mountain Breeze Drive. The Synchro outputs are enclosed for reference.

Table 3: Level-of-Service Summary for N Main Street at Givens Lane/Mountain Breeze Drive

CONDITION	LANE GROUP	AM PEAK HOUR				PM PEAK HOUR			
		Lane LOS	Lane Delay (sec)	Lane Queue (ft)	Overall LOS (Delay)	Lane LOS	Lane Delay (sec)	Lane Queue (ft)	Overall LOS (Delay)
Existing (2022) Conditions	EBL/T/R ¹	C	17	8	N/A ³	C	17	10	N/A ³
	WBL/T/R ¹	C	17	8		C	20	10	
	NBL/T/R ²	A	9	0		A	9	3	
	SBL/T/R ²	A	8	0		A	8	0	
No-Build (2027) Conditions	EBL/T/R ¹	C	19	10	N/A ³	C	22	18	N/A ³
	WBL/T/R ¹	C	18	10		C	25	18	
	NBL/T/R ²	A	9	3		A	9	3	
	SBL/T/R ²	A	8	0		A	9	0	
Build (2027) Conditions	EBL/T/R ¹	C	18	13	N/A ³	C	22	20	N/A ³
	WBL/T/R ¹	C	19	10		D	27	18	
	NBL/T/R ²	A	9	3		A	9	3	
	SBL/T/R ²	A	8	0		A	9	0	

1. Level of service for minor approach
2. Level of service for major-street left-turn movement
3. HCM methodology does not provide lane group or overall LOS, delay, and queue lengths for major street through movements or right turns at unsignalized intersections.

Capacity analysis indicates that the minor-street and major-street left-turn movements are expected to operate at LOS D or better during the AM and PM peak hours. While the westbound approach is expected to degrade one level of service during the PM peak hour when comparing the no-build to the build conditions, delays are only expected to increase by approximately 2 seconds. Additionally, no significant increase in queues is expected. Due to acceptable levels of service and minimal impacts from the proposed development, no improvements are recommended by the developer.



Table 4 summarizes the capacity analysis results for the existing unsignalized intersection of Givens Lane at Carroll Drive. The Synchro outputs are enclosed for reference.

Table 4: Level-of-Service Summary for Givens Lane at Carroll Drive

CONDITION	LANE GROUP	AM PEAK HOUR				PM PEAK HOUR			
		Lane LOS	Lane Delay (sec)	Lane Queue (ft)	Overall LOS (Delay)	Lane LOS	Lane Delay (sec)	Lane Queue (ft)	Overall LOS (Delay)
Existing (2022) Conditions	EBL/T ²	A	8	3	N/A ³	A	8	3	N/A ³
	WBT/R	-	-	-		-	-	-	
	SBL/R ¹	A	10	8		A	10	3	
No-Build (2027) Conditions	EBL/T ²	A	8	0	N/A ³	A	8	3	N/A ³
	WBT/R	-	-	-		-	-	-	
	SBL/R ¹	A	9	5		A	10	5	
Build (2027) Conditions	EBL/T ²	A	8	0	N/A ³	A	8	3	N/A ³
	WBT/R	-	-	-		-	-	-	
	SBL/R ¹	A	10	8		B	10	5	

1. Level of service for minor approach
2. Level of service for major-street left-turn movement
3. HCM methodology does not provide lane group or overall LOS, delay, and queue lengths for major street through movements or right turns at unsignalized intersections.

Capacity analysis indicates that the minor-street and major-street left-turn movements are expected to operate at LOS B or better during the AM and PM peak hours. Due to acceptable levels of service and minimal impacts from the proposed development, no improvements are recommended by the developer.

Table 5 summarizes the capacity analysis results for the existing roundabout intersection of Givens Lane and Progress Street. The Sidra outputs are enclosed for reference.

Table 5: Level-of-Service Summary for Givens Lane at Progress Street

CONDITION	LANE GROUP	AM PEAK HOUR				PM PEAK HOUR			
		Lane LOS	Lane Delay (sec)	Lane Queue (ft)	Overall LOS (Delay)	Lane LOS	Lane Delay (sec)	Lane Queue (ft)	Overall LOS (Delay)
Existing (2022) Conditions	EBL/T/R	A	3	4	A (4)	A	4	10	A (4)
	WBL/T/R	A	4	15		A	4	11	
	NBL/T/R	A	3	2		A	4	5	
	SBL/T/R	A	4	3		A	4	2	
No-Build (2027) Conditions	EBL/T/R	A	3	4	A (4)	A	4	11	A (4)
	WBL/T/R	A	4	19		A	4	14	
	NBL/T/R	A	3	3		A	4	6	
	SBL/T/R	A	4	4		A	4	2	
Build (2027) Conditions	EBL/T/R	A	3	4	A (4)	A	4	12	A (4)
	WBL/T/R	A	4	19		A	4	14	
	NBL/T/R	A	3	3		A	4	7	
	SBL/T/R	A	4	5		A	5	3	

Capacity analysis indicates that all approaches are expected to operate at LOS A during the AM and PM peak hours. Due to acceptable levels of service and minimal impacts from the proposed development, no improvements are recommended by the developer.

Recommendations

Based on the traffic capacity analysis, all study intersections will function at an acceptable overall level-of-service at build out of the proposed community. As mentioned previously, left turn lanes are warranted on Main Street at both Countryside Court and Givens Lane without the completion of the proposed development; therefore, no improvements should be required by the developer for this project. We appreciate your attention to this matter. Please contact me at (336) 714-0112 if you have any questions about this report.

Sincerely yours,

Ramey Kemp & Associates, Inc.



A handwritten signature in black ink that reads "Chase T. Smith".

3-28-2022

Chase Smith, P.E.

Enclosures: Figures, Traffic count data, VDOT Turn Lane Warrants, Synchro output

Copy to: Mr. Steven Semones, Balzer & Associates

FIGURES

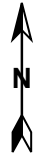
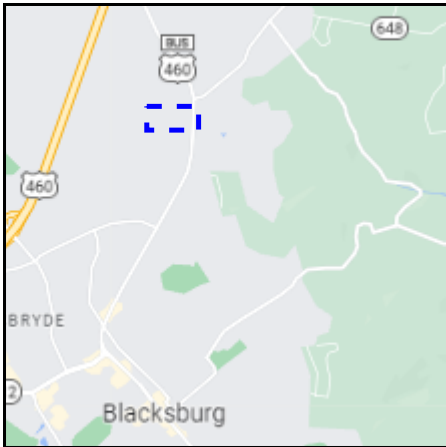

LEGEND

-  Study Intersection
-  Proposed Interconnectivity to the Site
-  Study Area



Northside Subdivision
Blacksburg, VA

Site Location Map

Scale: Not to Scale Figure 1



BALZER & ASSOCIATES
PLANNERS / ARCHITECTS
ENGINEERS / SURVEYORS

Roanoke / Richmond
New River Valley
Shenandoah Valley
www.balzer.cc
80 College Street
Suite H
Christiansburg, VA 24073
540.381.4290

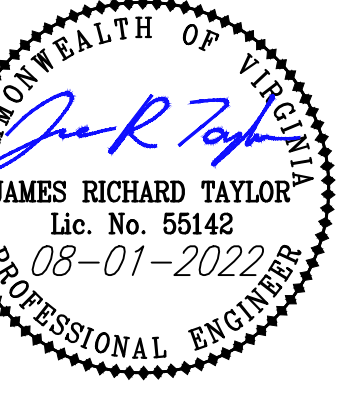

NORTHSIDE PARK - REVISED SECTION XII
PRELIMINARY PLAT
OVERALL LAYOUT

MOUNT LABOR MAGISTERIAL DISTRICT
TOWN OF BLACKSBURG, VIRGINIA

DRAWN BY: SJW
DESIGNED BY: SJW
CHECKED BY: JRT
DATE: 8/1/2022
SCALE: AS SHOWN
REVISIONS:

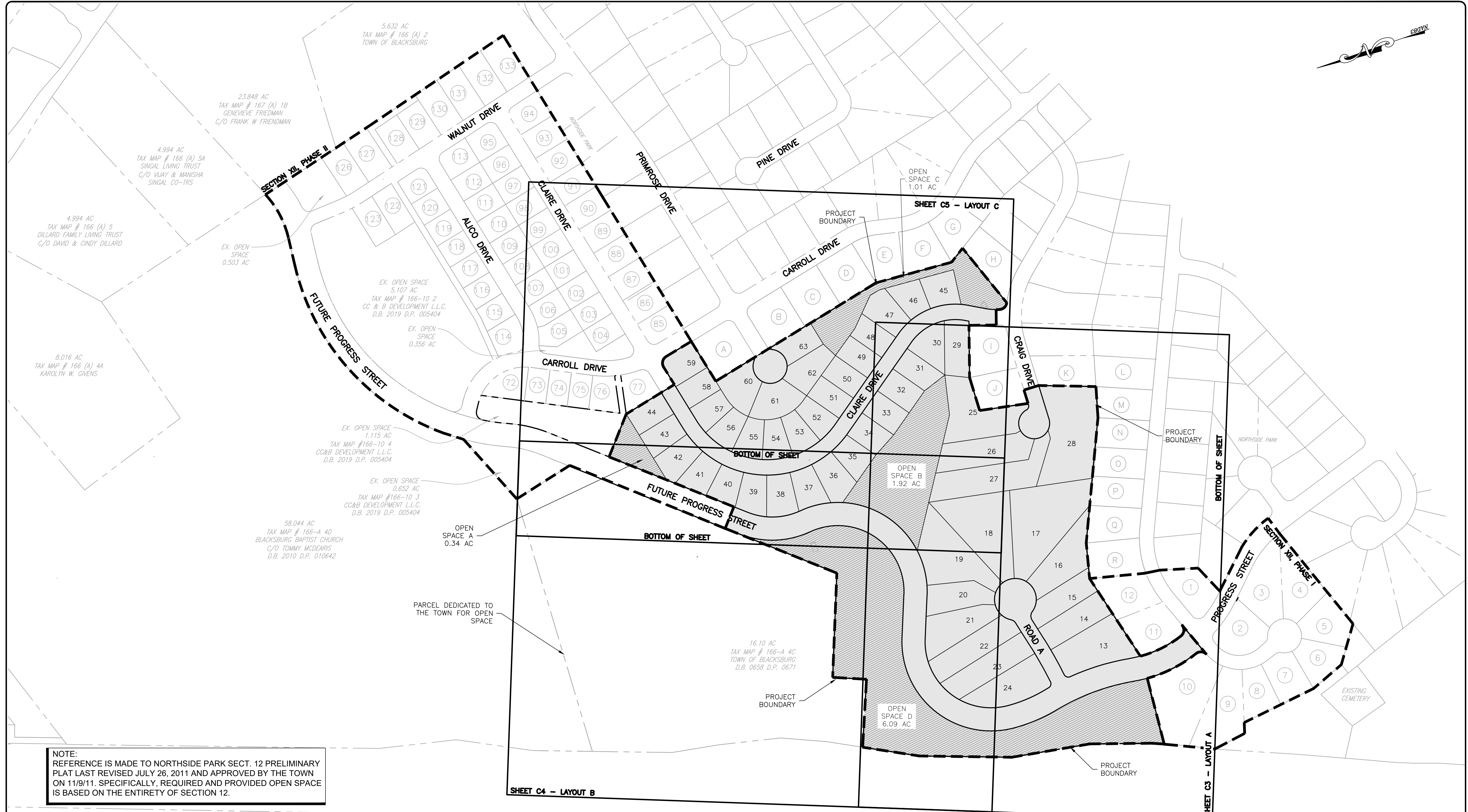
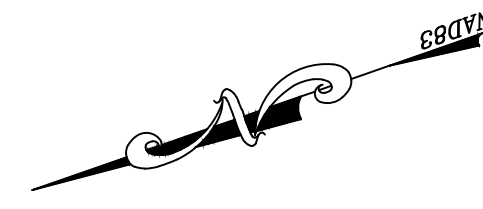

NOTE:
REFERENCE IS MADE TO NORTHSIDE PARK SECT. 12 PRELIMINARY PLAT LAST REVISED JULY 26, 2011 AND APPROVED BY THE TOWN ON 11/9/11. SPECIFICALLY, REQUIRED AND PROVIDED OPEN SPACE IS BASED ON THE ENTIRETY OF SECTION 12.

ADJACENT PROPERTY OWNERS:

- | | | | | | | | | | | | | | | | | | | | | | |
|---|---|--|---|---|---|--|--|---|--|---|---|---|---|--|---|---|---|---|--|--|--|
| <p>⑩ TRAVIS AND MEGAN ESCHENMANN
TAX #166-17 10
D.B. 2008 PG. 011143
P.B. 0025 PG. 0108
ZONING: R-4</p> | <p>① SCOTTIE AND BILLIE WYATT
TAX #166-17 11
D.B. 2017 PG. 006588
P.B. 0025 PG. 108
ZONING: R-4</p> | <p>⑫ KIRK AND MELISSA CAMERON
TAX #166-17 12
D.B. 2017 PG. 006588
P.B. 0025 PG. 0108
ZONING: R-4</p> | <p>⑪⑦ CC&B DEVELOPMENT LLC
TAX #166-10 77
2019 PG. 005404
INST # - 2019004424
ZONING: R-4</p> | <p>① MOHAMED KHALED HASSOUNA AND ALI DINA FATH
TAX #166-1 10
D.B. 2016 PG. 001057
INST. #2016001637
ZONING: R-4</p> | <p>② GREGORY B IRWIN
TAX #166-1 9
D.B. 2020 PG. 008205
P.B. 0006 PG. 0104
ZONING: R-4</p> | <p>③ HALLAUER LIVING TRUST
C/O WILLIAM L HALLAUER JR CO-TRS
TAX #166-1 8
D.B. 2014 PG. 008216
P.B. 0006 PG. 0104
ZONING: R-4</p> | <p>④ HAO SHI AND JIE RONG
TAX #166-1 7
D.B. 2013 PG. 007550
P.B. 0006 PG. 0104
ZONING: R-4</p> | <p>⑤ JESS JONES AND KATHLEEN GILBERT
TAX #166-1 6
D.B. 2012 PG. 009140
P.B. 0006 PG. 0104
ZONING: R-4</p> | <p>⑥ WILLIAM AND TERESA PRICE
TAX #166-1 5
D.B. 2006 PG. 003777
P.B. 0006 PG. 0104
ZONING: R-4</p> | <p>⑦ ARTHUR MOOK AND JENNIFER MORGAN
TAX #166-1 4
D.B. 2014 PG. 004029
P.B. 0847 PG. 0616
ZONING: R-4</p> | <p>⑧ JOSEPH AND LESLIE PARADISO
TAX #166-1 01
D.B. 2013 PG. 007550
P.B. 0016 PG. 0692
ZONING: R-4</p> | <p>⑨ ADAM AND KERRI EDWARDS
TAX #166-7 10
D.B. 2016 PG. 003014
P.B. 0016 PG. 0692
ZONING: R-4</p> | <p>⑩ GERARD AND JANICE TESTI
TAX #166-1 9
D.B. 2010 PG. 005951
P.B. 0016 PG. 0692
ZONING: R-4</p> | <p>⑪ ROBERT AND GAYLE KIRBY
TAX #166-10 78
D.B. 0991 PG. 0195
P.B. 0847 PG. 0692
ZONING: R-4</p> | <p>⑫ SAGHAN MAROOF
TAX #166-7 9
D.B. 1039 PG. 0149
P.B. 1039 PG. 0152
ZONING: R-4</p> | <p>⑬ CHRISTOPHER SHIVELY AND RICHARD SHIELD
TAX #166-7 10
D.B. 2002 PG. 005787
P.B. 0015 PG. 0195
ZONING: R-4</p> | <p>⑭ MING XU AND PING YAN
TAX #166-9 18
D.B. 2004 PG. 005118
P.B. 0862 PG. 0005
ZONING: R-4</p> | <p>⑮ PETER WILLENSTEIN AND HO SOOKHAN
TAX #166-8 19
D.B. 0780 PG. 0488
P.B. 0015 PG. 0370
ZONING: R-4</p> | <p>⑯ DAVID R BEVAN III AND PATRICE ERNST BEVAN
TAX #166-8 20
D.B. 1008 PG. 0049
P.B. 1008 PG. 0051
ZONING: R-4</p> | <p>⑰ STEVEN AND HOLLY ROSS
TAX #166-9 21
D.B. 2006 PG. 006622
P.B. 0015 PG. 0370
ZONING: R-4</p> | <p>⑱ CLARENCE AND LINDA WASKEY
TAX #166-8 22
D.B. 2010 PG. 005172
P.B. 0015 PG. 0370
ZONING: R-4</p> |
|---|---|--|---|---|---|--|--|---|--|---|---|---|---|--|---|---|---|---|--|--|--|

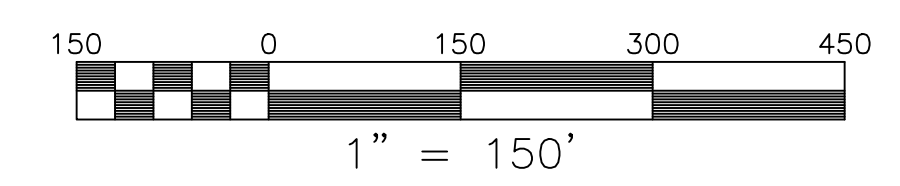

APPROVAL BLOCK	
BLACKSBURG TOWN PLANNER	DATE
BLACKSBURG TOWN ENGINEER	DATE

J:\2020\24220049\01 NORTHSIDE PARK\SECTION XII\NORTHSIDE PARK\REVISED PRELIMINARY PLAT.dwg PLOTTED: 8/1/2022 1:38:42 PM

LEGEND

- Unsignalized Intersection
- ⊙ Round-a-bout Intersection
- ➔ Existing Lane
- x' Storage (In Feet)
-  Posted Speed Limit

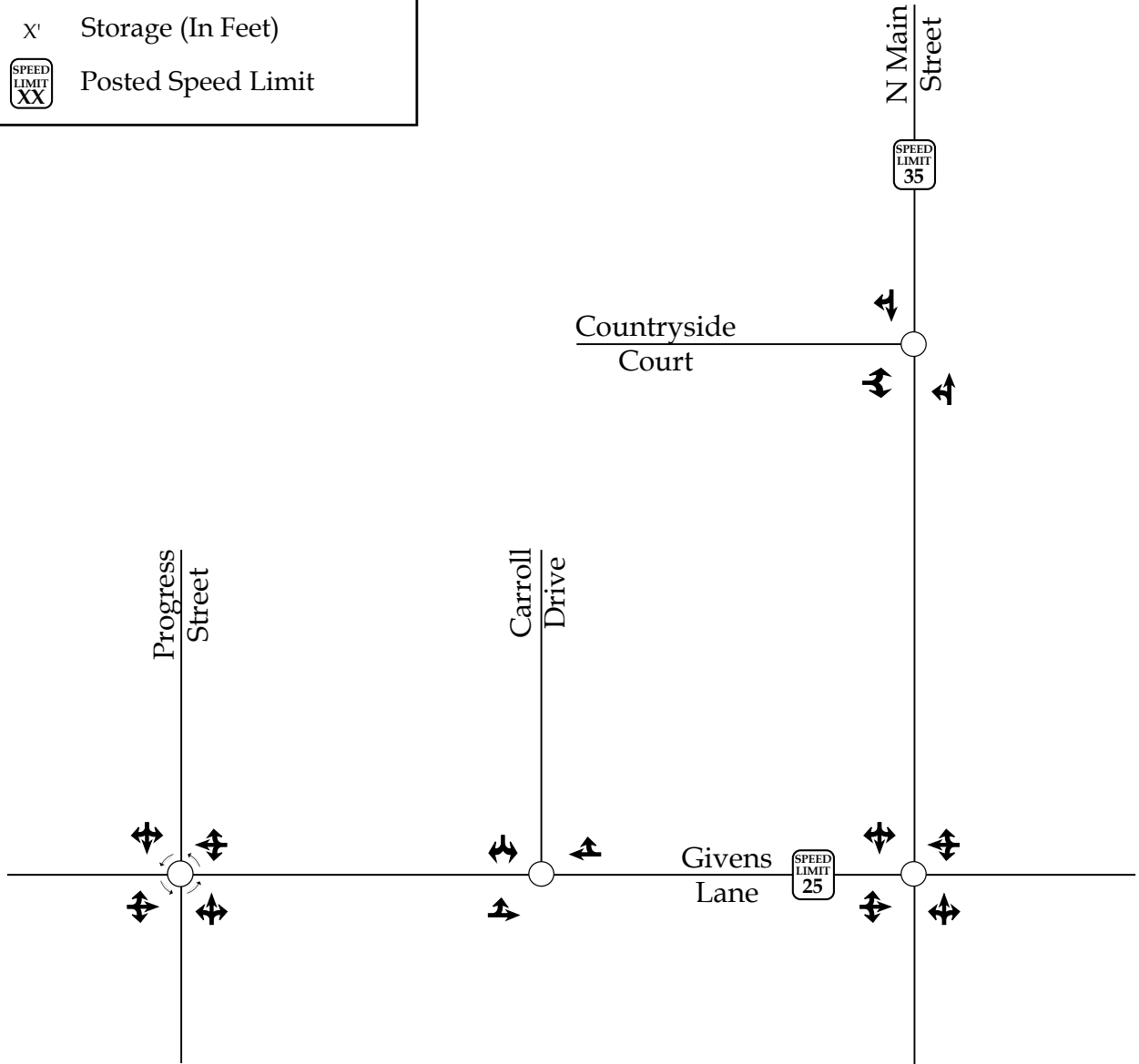

Northside Subdivision
Blacksburg, VA

2022 Existing
Lane Configurations

Scale: Not to Scale

Figure 3

LEGEND

- Unsignalized Intersection
- ⊙ Round-a-bout Intersection
- X / Y → Weekday AM / PM Peak Hour Traffic

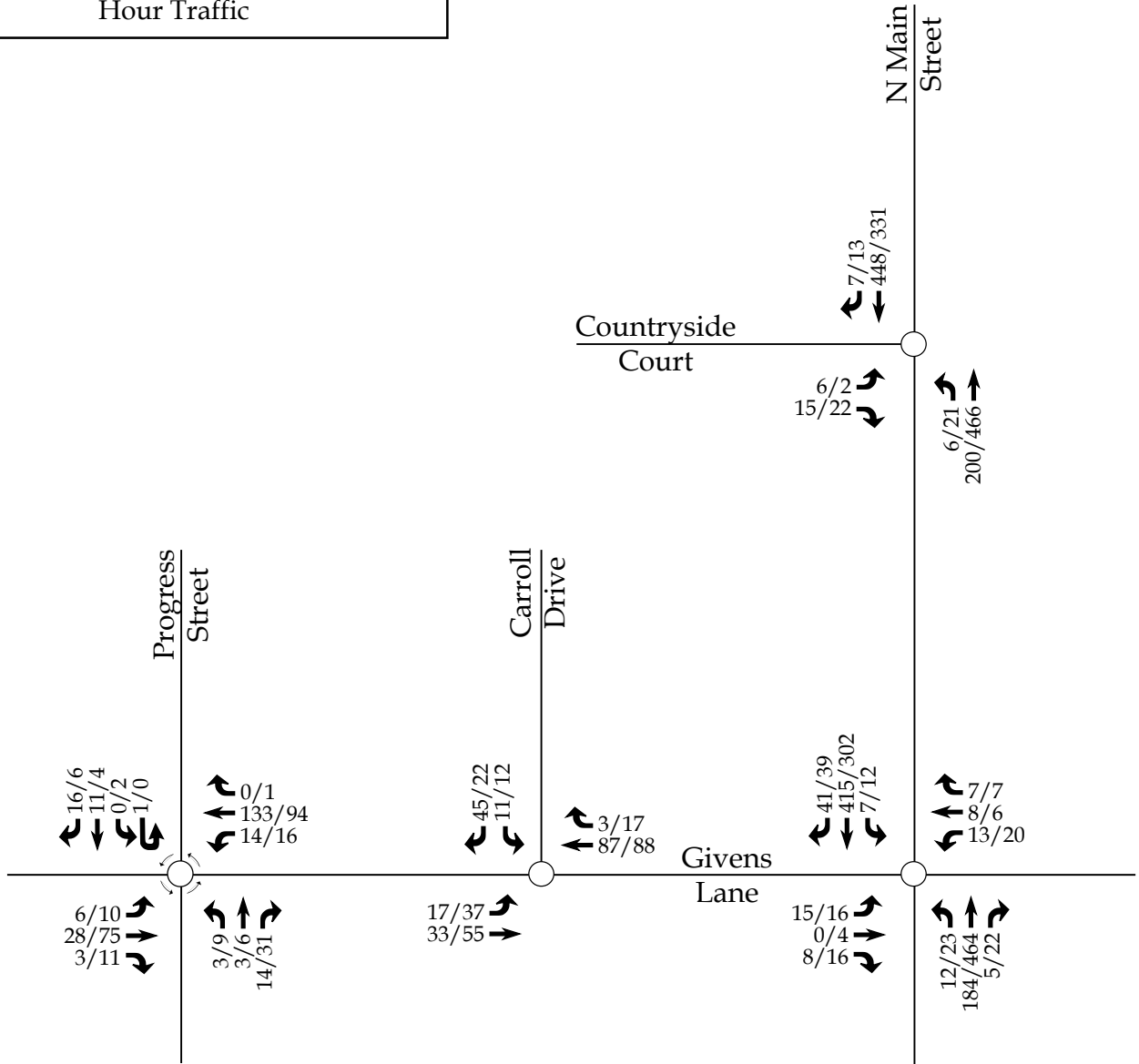

Northside Subdivision
Blacksburg, VA

2022 Existing
Peak Hour Traffic

Scale: Not to Scale

Figure 4

LEGEND

- Unsignalized Intersection
- ⊙ Round-a-bout Intersection
- X / Y → Weekday AM / PM Peak Hour Traffic

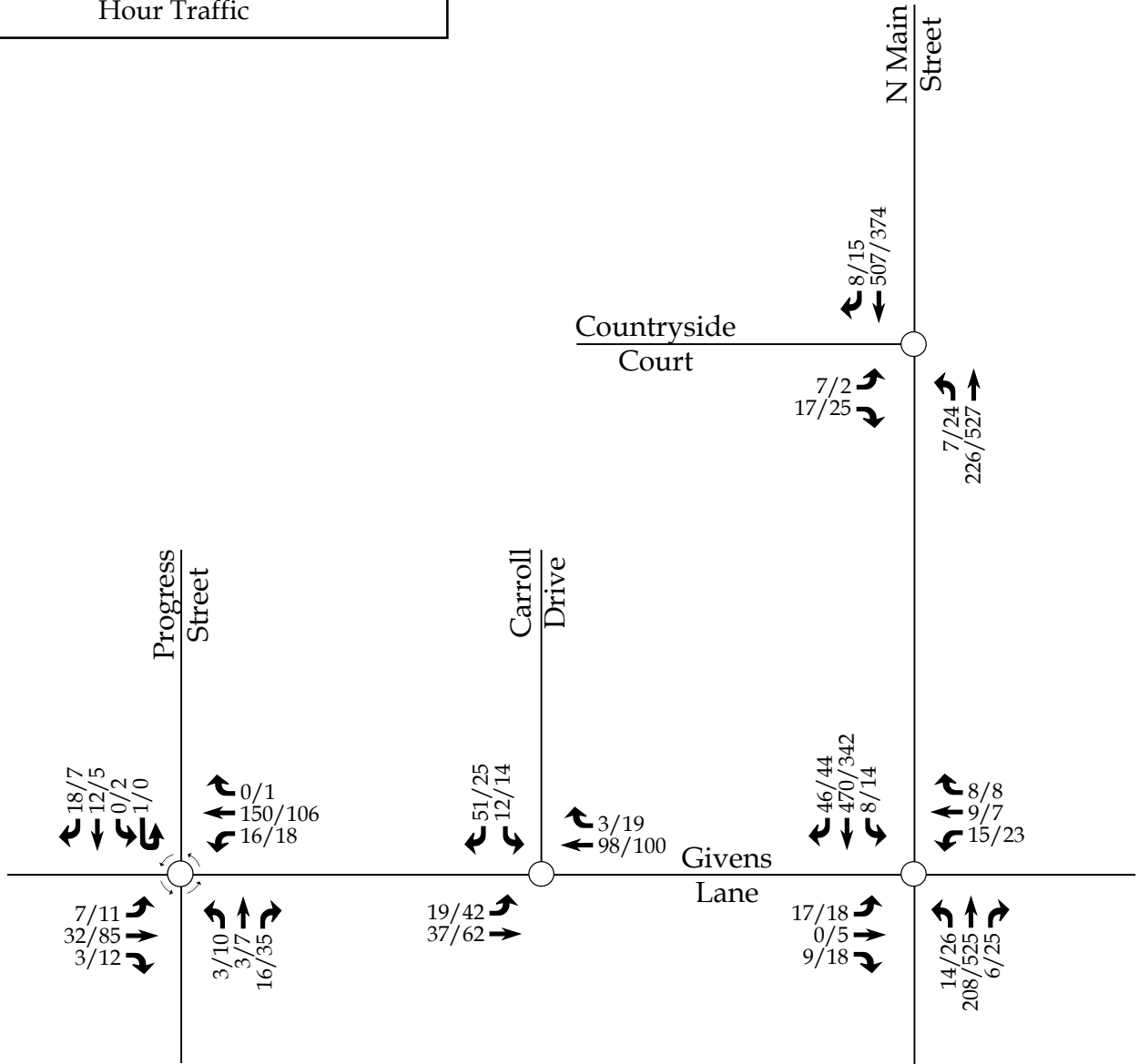

Northside Subdivision
Blacksburg, VA

2027 Projected
Peak Hour Traffic

Scale: Not to Scale

Figure 5

LEGEND

- Unsignalized Intersection
- ⊙ Round-a-bout Intersection
- X / Y → Weekday AM / PM Peak Hour Adjacent Development Trips

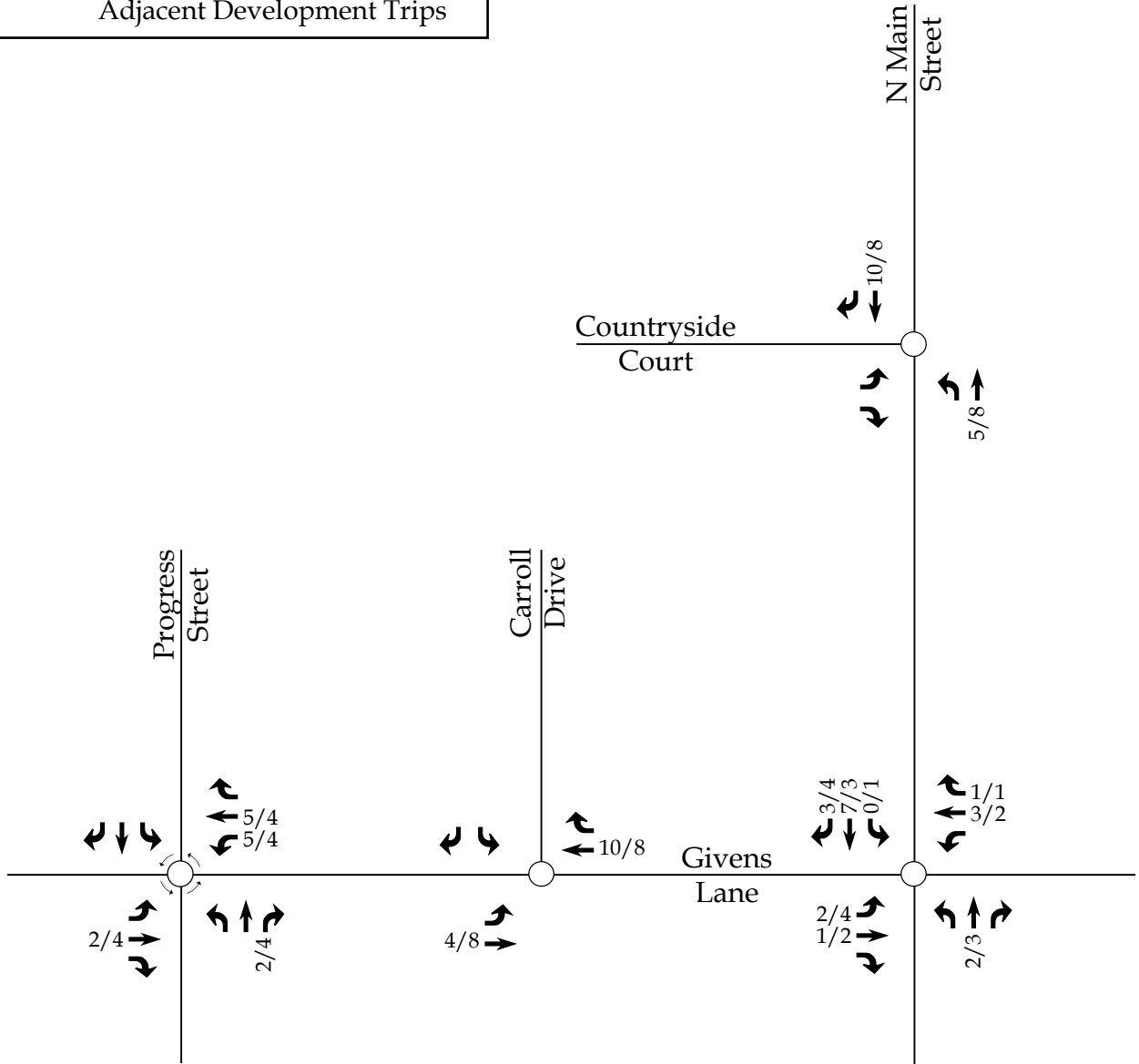

Northside Subdivision
Blacksburg, VA

Peak Hour Adjacent
Development Trips

Scale: Not to Scale

Figure 6

LEGEND

- Unsignalized Intersection
- ⊙ Round-a-bout Intersection
- X / Y → Weekday AM / PM Peak Hour Traffic

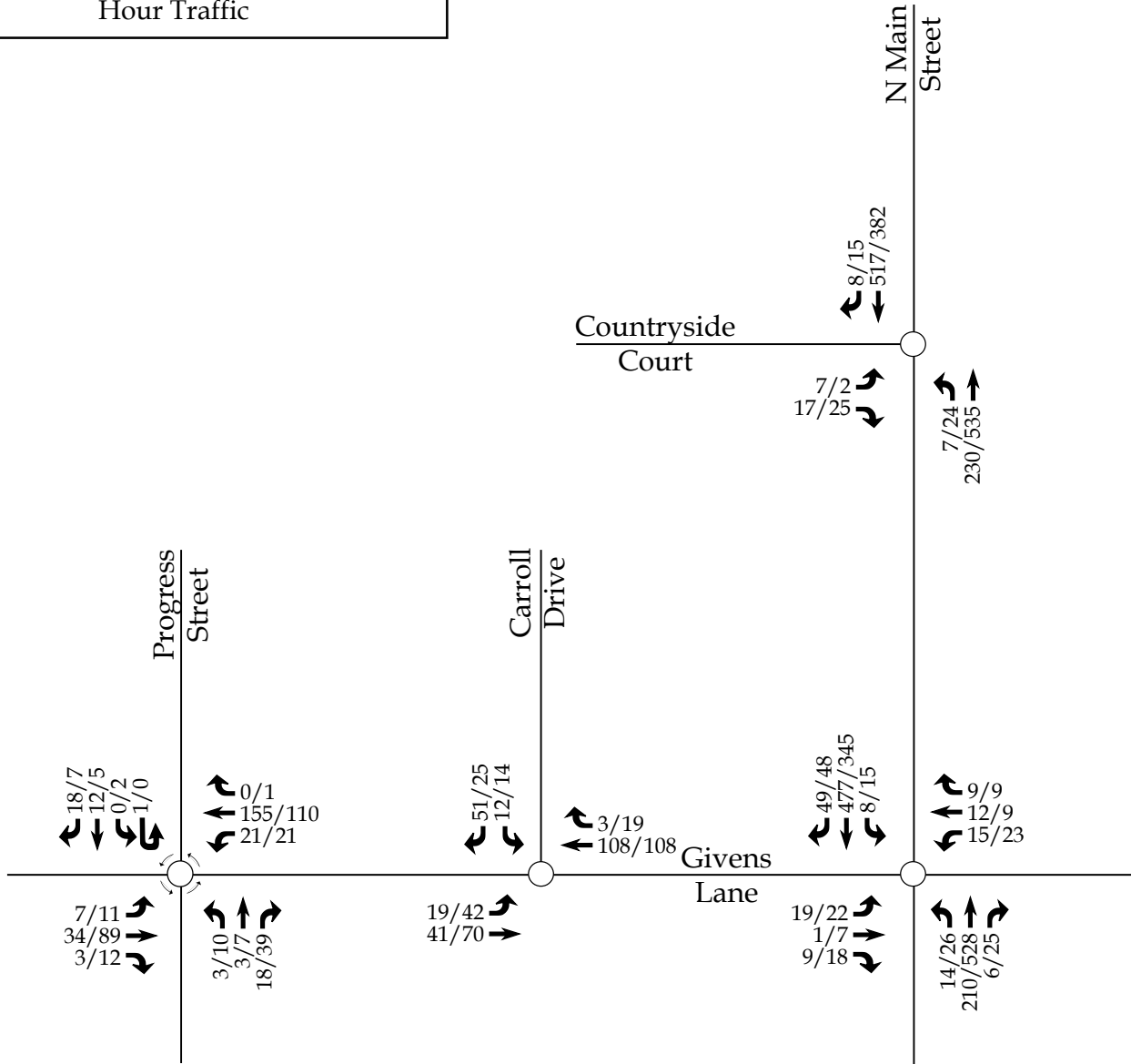

	<p>Northside Subdivision Blacksburg, VA</p>	<p>2027 No-Build Peak Hour Traffic</p>	
		<p>Scale: Not to Scale</p>	<p>Figure 7</p>

LEGEND

- Unsignalized Intersection
- ⊙ Round-a-bout Intersection
- x% → Entering Trip Distribution
- (Y%) → Exiting Trip Distribution
- ▭ XX% Regional Trip Distribution

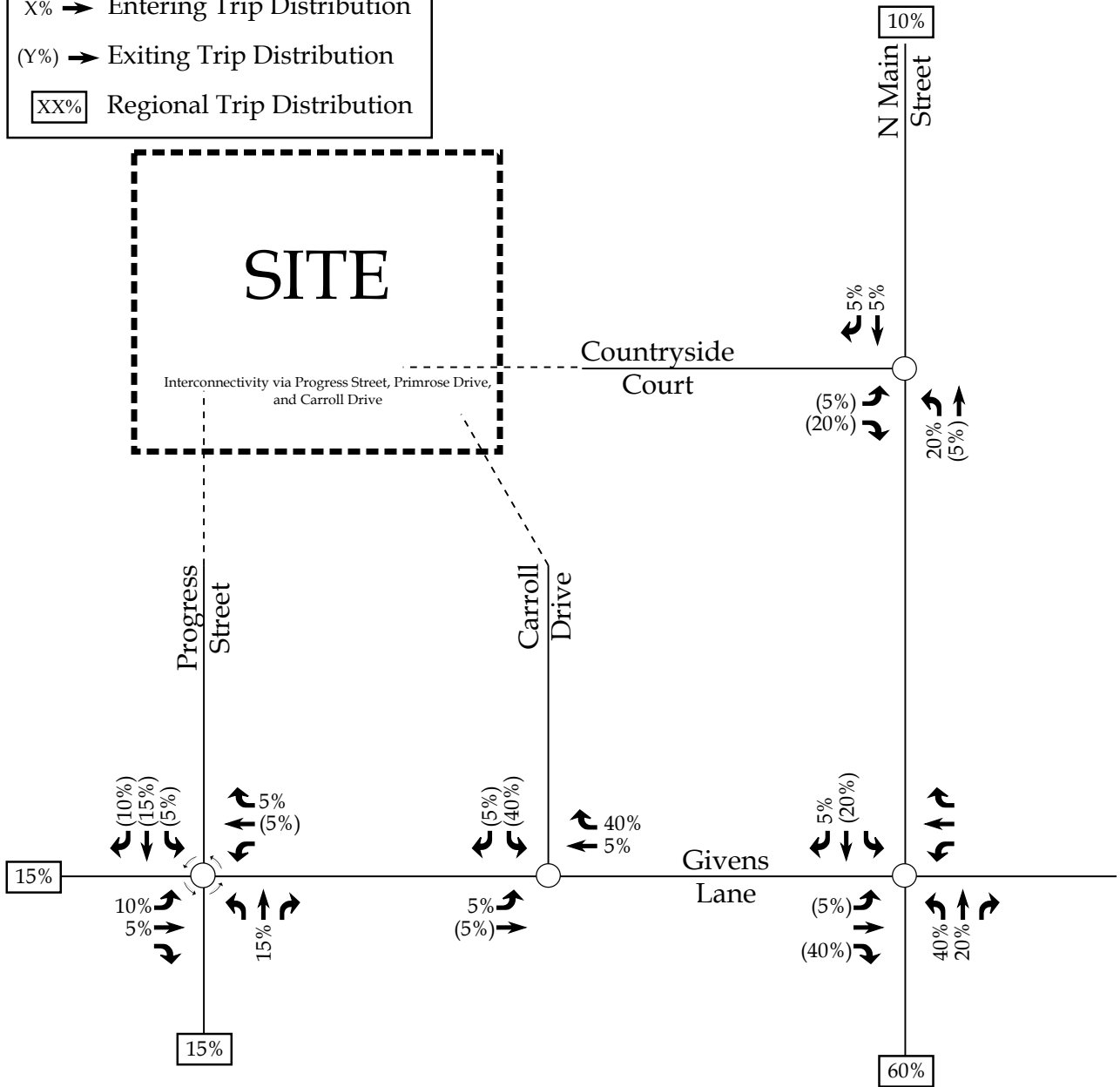

Northside Subdivision
Blacksburg, VA

Site Trip Distribution

Scale: Not to Scale

Figure 8

LEGEND

- Unsignalized Intersection
- ⊙ Round-a-bout Intersection
- X / Y → Hour Site Trips

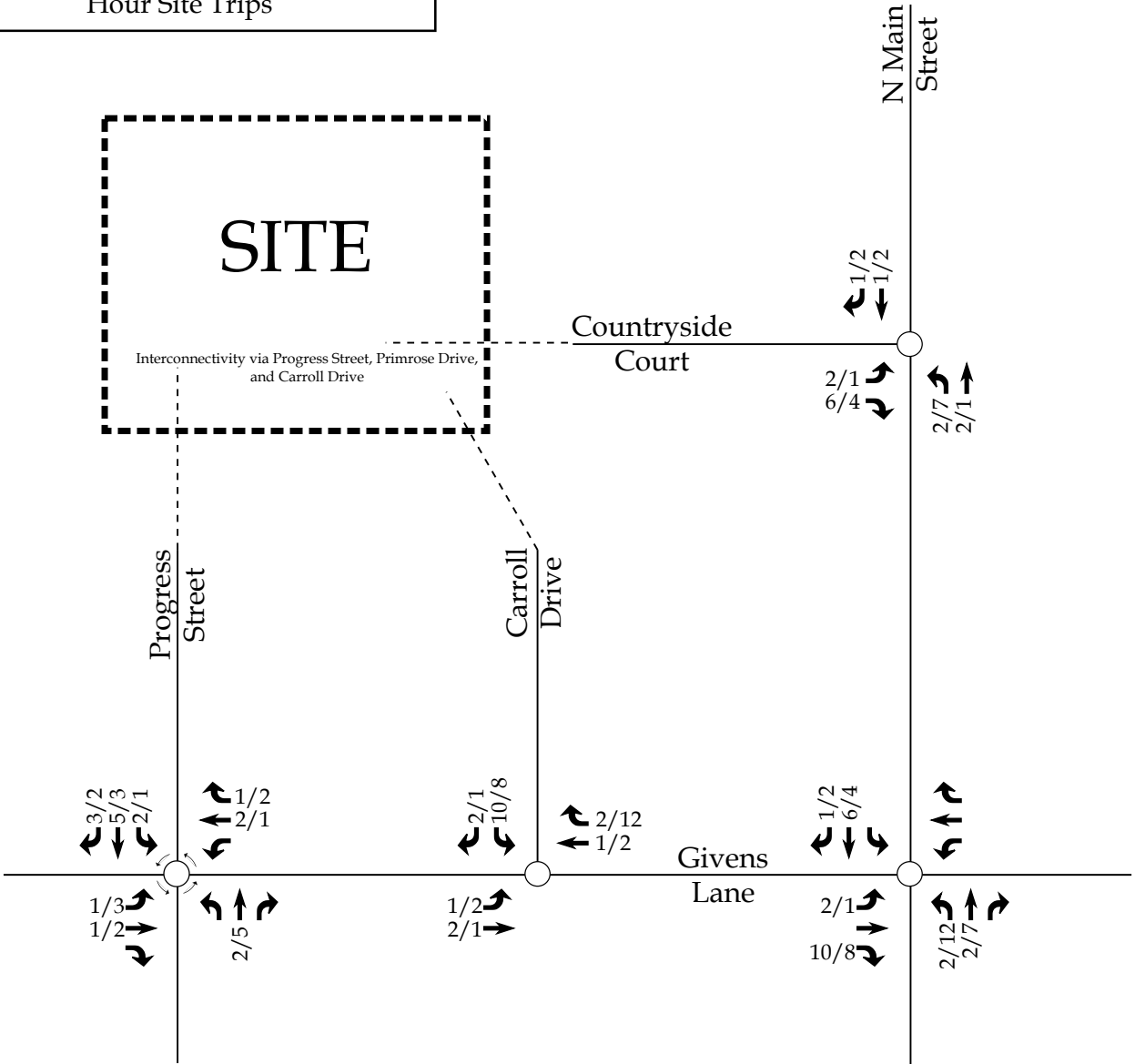

Northside Subdivision
Blacksburg, VA

Site Trip Assignment

Scale: Not to Scale

Figure 9

LEGEND

- Unsignalized Intersection
- ⊙ Round-a-bout Intersection

X / Y → Weekday AM / PM Peak Hour Traffic

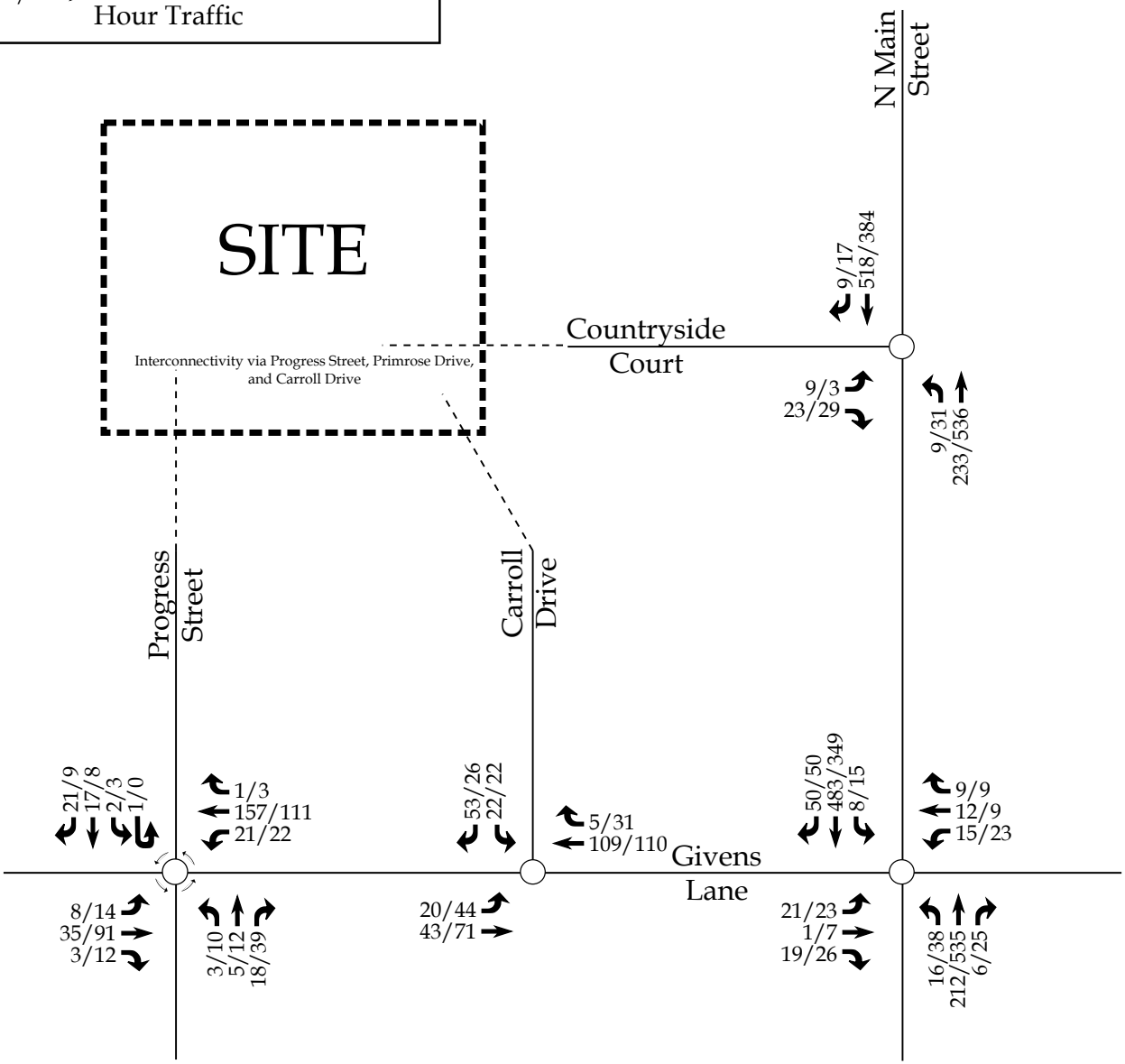

Northside Subdivision
Blacksburg, VA

2027 Build
Peak Hour Traffic

Scale: Not to Scale | Figure 10

COUNT DATA



TRAFFIC DATA COLLECTION

File Name : Blacksburg(Givens Lane and Carroll Drive) 10-18
 Site Code :
 Start Date : 10/18/2022
 Page No : 1

Groups Printed- Cars + - Trucks

Start Time	Carroll Drive Southbound					Givens Lane Westbound					Givens Lane Eastbound					Int. Total
	Right	Left	UTrn	Peds	App. Total	Right	Thru	UTrn	Peds	App. Total	Thru	Left	UTrn	Peds	App. Total	
07:00 AM	6	1	0	0	7	0	8	0	0	8	4	4	0	0	8	23
07:15 AM	8	3	0	0	11	0	16	0	0	16	9	4	0	0	13	40
07:30 AM	19	4	0	0	23	1	31	0	0	32	11	3	0	0	14	69
07:45 AM	8	1	0	0	9	0	20	0	0	20	7	2	0	0	9	38
Total	41	9	0	0	50	1	75	0	0	76	31	13	0	0	44	170
08:00 AM	10	3	0	0	13	2	20	0	0	22	6	8	0	0	14	49
08:15 AM	9	3	0	0	12	2	15	0	0	17	5	4	0	0	9	38
08:30 AM	12	1	0	0	13	1	22	0	0	23	10	3	0	2	15	51
08:45 AM	9	7	0	0	16	1	15	0	0	16	9	7	0	1	17	49
Total	40	14	0	0	54	6	72	0	0	78	30	22	0	3	55	187
09:00 AM	9	5	0	0	14	1	21	0	0	22	4	2	0	0	6	42
09:15 AM	3	1	0	0	4	2	10	0	0	12	10	4	0	0	14	30
09:30 AM	8	2	0	0	10	0	17	0	1	18	9	2	0	0	11	39
09:45 AM	4	1	0	0	5	0	6	0	0	6	7	0	0	0	7	18
Total	24	9	0	0	33	3	54	0	1	58	30	8	0	0	38	129
10:00 AM	6	0	0	0	6	2	9	0	0	11	9	4	0	1	14	31
10:15 AM	4	2	0	0	6	1	12	0	0	13	5	4	1	0	10	29
10:30 AM	7	4	0	0	11	1	17	0	0	18	16	2	0	0	18	47
10:45 AM	0	1	0	1	2	2	8	0	1	11	13	1	0	0	14	27
Total	17	7	0	1	25	6	46	0	1	53	43	11	1	1	56	134
11:00 AM	7	2	0	0	9	2	9	0	0	11	4	2	0	0	6	26
11:15 AM	2	3	0	1	6	2	14	0	1	17	8	3	0	0	11	34
11:30 AM	9	2	0	0	11	0	9	0	0	9	8	2	0	0	10	30
11:45 AM	4	0	0	0	4	3	6	0	0	9	9	4	0	0	13	26
Total	22	7	0	1	30	7	38	0	1	46	29	11	0	0	40	116
12:00 PM	4	2	0	0	6	1	7	0	0	8	8	8	0	0	16	30
12:15 PM	3	2	0	0	5	0	11	0	0	11	11	4	0	0	15	31
12:30 PM	2	3	0	0	5	2	9	0	0	11	3	3	0	0	6	22
12:45 PM	3	4	0	0	7	0	5	0	1	6	5	4	0	0	9	22
Total	12	11	0	0	23	3	32	0	1	36	27	19	0	0	46	105
01:00 PM	2	0	0	0	2	1	14	0	0	15	9	8	0	0	17	34
01:15 PM	2	6	0	0	8	2	10	0	0	12	6	1	0	0	7	27
01:30 PM	2	4	0	0	6	5	10	0	0	15	9	5	0	0	14	35
01:45 PM	3	1	0	0	4	4	6	0	0	10	7	5	0	0	12	26
Total	9	11	0	0	20	12	40	0	0	52	31	19	0	0	50	122
02:00 PM	3	5	0	0	8	4	9	0	1	14	3	4	0	0	7	29
02:15 PM	6	2	0	0	8	4	9	0	0	13	3	6	0	1	10	31
02:30 PM	4	1	0	0	5	1	17	0	0	18	11	4	0	0	15	38
02:45 PM	7	2	0	0	9	2	9	0	0	11	8	6	0	0	14	34
Total	20	10	0	0	30	11	44	0	1	56	25	20	0	1	46	132



TRAFFIC DATA COLLECTION

File Name : Blacksburg(Givens Lane and Carroll Drive) 10-18

Site Code :

Start Date : 10/18/2022

Page No : 2

Groups Printed- Cars + - Trucks

Start Time	Carroll Drive Southbound					Givens Lane Westbound					Givens Lane Eastbound					Int. Total
	Right	Left	UTrn	Peds	App. Total	Right	Thru	UTrn	Peds	App. Total	Thru	Left	UTrn	Peds	App. Total	
03:00 PM	4	6	0	0	10	0	10	0	0	10	15	8	0	1	24	44
03:15 PM	7	3	0	0	10	3	13	0	1	17	10	10	0	0	20	47
03:30 PM	8	1	0	0	9	1	15	0	0	16	7	10	0	1	18	43
03:45 PM	7	3	0	0	10	6	18	0	0	24	18	8	0	0	26	60
Total	26	13	0	0	39	10	56	0	1	67	50	36	0	2	88	194
04:00 PM	5	1	0	0	6	5	20	0	0	25	8	10	0	0	18	49
04:15 PM	7	2	0	0	9	3	21	0	0	24	12	5	0	0	17	50
04:30 PM	5	2	0	0	7	1	20	0	0	21	11	6	0	0	17	45
04:45 PM	6	3	0	0	9	0	20	0	0	20	14	8	0	0	22	51
Total	23	8	0	0	31	9	81	0	0	90	45	29	0	0	74	195
05:00 PM	6	2	0	0	8	3	30	0	0	33	13	11	0	2	26	67
05:15 PM	5	4	0	0	9	8	19	0	0	27	13	9	0	1	23	59
05:30 PM	5	3	0	1	9	6	19	0	1	26	15	9	0	0	24	59
05:45 PM	2	2	0	0	4	1	16	0	2	19	13	10	0	0	23	46
Total	18	11	0	1	30	18	84	0	3	105	54	39	0	3	96	231
06:00 PM	10	3	0	0	13	3	26	0	1	30	14	5	0	1	20	63
06:15 PM	11	1	0	0	12	6	20	0	0	26	12	6	0	0	18	56
06:30 PM	1	2	0	0	3	1	16	0	0	17	10	5	0	0	15	35
06:45 PM	7	5	0	0	12	4	9	0	0	13	17	7	0	0	24	49
Total	29	11	0	0	40	14	71	0	1	86	53	23	0	1	77	203
Grand Total	281	121	0	3	405	100	693	0	10	803	448	250	1	11	710	1918
Apprch %	69.4	29.9	0	0.7		12.5	86.3	0	1.2		63.1	35.2	0.1	1.5		
Total %	14.7	6.3	0	0.2	21.1	5.2	36.1	0	0.5	41.9	23.4	13	0.1	0.6	37	
Cars +	278	118	0	2	398	99	660	0	9	768	419	242	1	11	673	1839
% Cars +	98.9	97.5	0	66.7	98.3	99	95.2	0	90	95.6	93.5	96.8	100	100	94.8	95.9
Trucks	3	3	0	1	7	1	33	0	1	35	29	8	0	0	37	79
% Trucks	1.1	2.5	0	33.3	1.7	1	4.8	0	10	4.4	6.5	3.2	0	0	5.2	4.1



TRAFFIC DATA COLLECTION

File Name : Blacksburg(Givens Lane and Carroll Drive) 10-18
 Site Code :
 Start Date : 10/18/2022
 Page No : 3

Start Time	Carroll Drive Southbound					Givens Lane Westbound					Givens Lane Eastbound					Int. Total
	Right	Left	UTrn	Peds	App. Total	Right	Thru	UTrn	Peds	App. Total	Thru	Left	UTrn	Peds	App. Total	
Peak Hour Analysis From 07:00 AM to 08:45 AM - Peak 1 of 1																
Peak Hour for Entire Intersection Begins at 07:15 AM																
07:15 AM	8	3	0	0	11	0	16	0	0	16	9	4	0	0	13	40
07:30 AM	19	4	0	0	23	1	31	0	0	32	11	3	0	0	14	69
07:45 AM	8	1	0	0	9	0	20	0	0	20	7	2	0	0	9	38
08:00 AM	10	3	0	0	13	2	20	0	0	22	6	8	0	0	14	49
Total Volume	45	11	0	0	56	3	87	0	0	90	33	17	0	0	50	196
% App. Total	80.4	19.6	0	0		3.3	96.7	0	0		66	34	0	0		
PHF	.592	.688	.000	.000	.609	.375	.702	.000	.000	.703	.750	.531	.000	.000	.893	.710

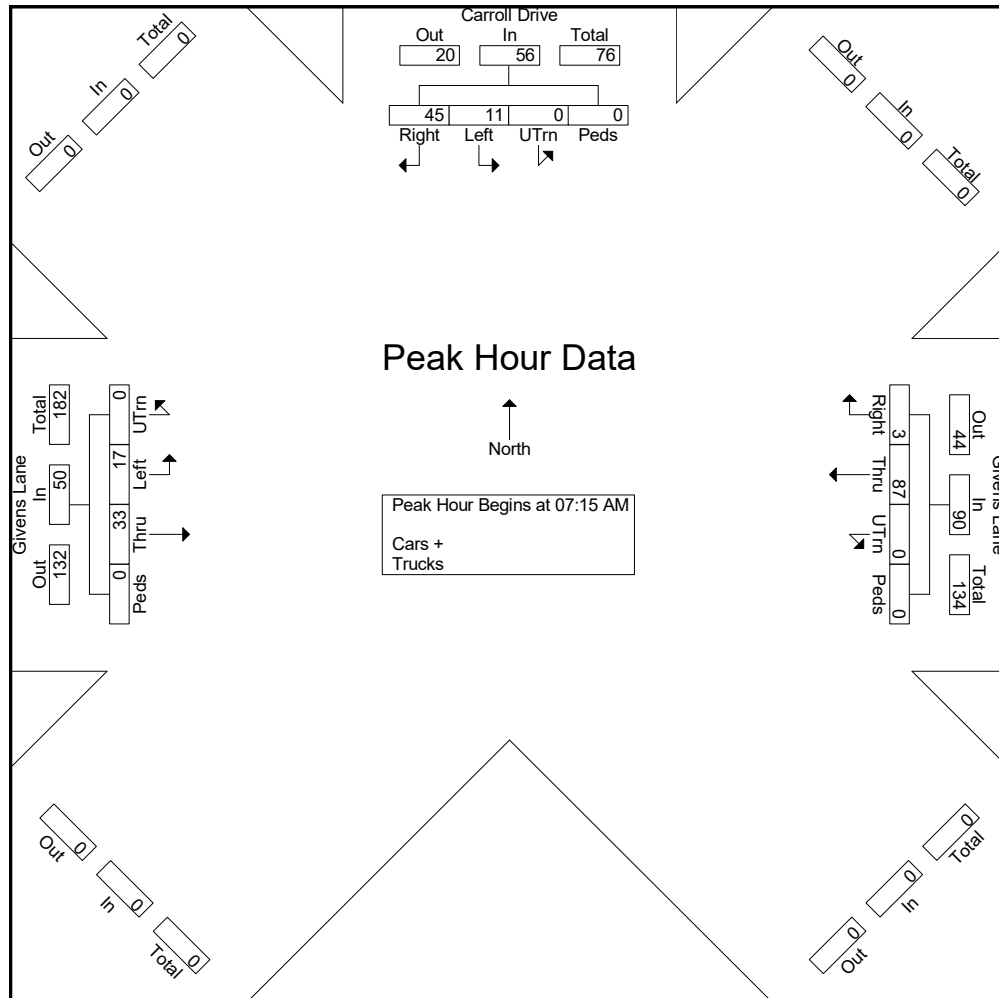



TRAFFIC DATA COLLECTION

File Name : Blacksburg(Givens Lane and Carroll Drive) 10-18
 Site Code :
 Start Date : 10/18/2022
 Page No : 4

Start Time	Carroll Drive Southbound					Givens Lane Westbound					Givens Lane Eastbound					Int. Total
	Right	Left	UTrn	Peds	App. Total	Right	Thru	UTrn	Peds	App. Total	Thru	Left	UTrn	Peds	App. Total	
Peak Hour Analysis From 04:00 PM to 05:45 PM - Peak 1 of 1																
Peak Hour for Entire Intersection Begins at 04:45 PM																
04:45 PM	6	3	0	0	9	0	20	0	0	20	14	8	0	0	22	51
05:00 PM	6	2	0	0	8	3	30	0	0	33	13	11	0	2	26	67
05:15 PM	5	4	0	0	9	8	19	0	0	27	13	9	0	1	23	59
05:30 PM	5	3	0	1	9	6	19	0	1	26	15	9	0	0	24	59
Total Volume	22	12	0	1	35	17	88	0	1	106	55	37	0	3	95	236
% App. Total	62.9	34.3	0	2.9		16	83	0	0.9		57.9	38.9	0	3.2		
PHF	.917	.750	.000	.250	.972	.531	.733	.000	.250	.803	.917	.841	.000	.375	.913	.881

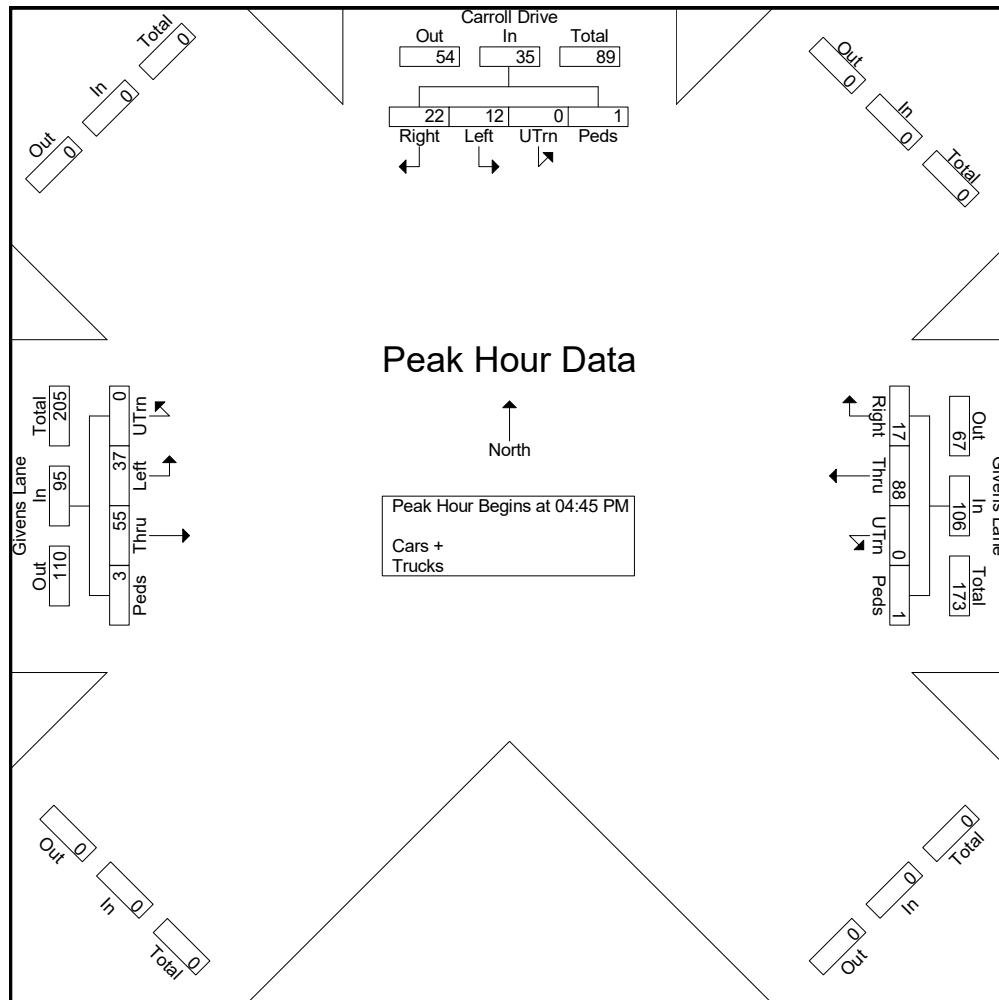



TRAFFIC DATA COLLECTION

File Name : Blacksburg(Givens Lane and Carroll Drive)10-19
 Site Code :
 Start Date : 10/19/2022
 Page No : 1

Groups Printed- Cars + - Trucks

Start Time	Carroll Drive Southbound					Givens Lane Westbound					Givens Lane Eastbound					Int. Total
	Right	Left	UTrn	Peds	App. Total	Right	Thru	UTrn	Peds	App. Total	Thru	Left	UTrn	Peds	App. Total	
07:00 AM	6	0	0	0	6	0	6	0	0	6	3	1	0	0	4	16
07:15 AM	7	3	0	0	10	0	13	0	0	13	6	3	0	0	9	32
07:30 AM	14	1	0	0	15	1	29	0	1	31	9	5	0	0	14	60
07:45 AM	12	2	0	0	14	2	23	0	0	25	7	2	0	0	9	48
Total	39	6	0	0	45	3	71	0	1	75	25	11	0	0	36	156
08:00 AM	2	2	0	0	4	0	17	0	0	17	10	3	0	0	13	34
08:15 AM	11	4	0	0	15	0	9	0	0	9	6	3	0	0	9	33
08:30 AM	13	5	0	0	18	1	27	0	0	28	8	1	0	1	10	56
08:45 AM	12	1	0	0	13	1	22	0	0	23	5	3	0	1	9	45
Total	38	12	0	0	50	2	75	0	0	77	29	10	0	2	41	168
09:00 AM	3	3	0	0	6	5	16	0	0	21	8	7	0	0	15	42
09:15 AM	7	1	0	0	8	2	4	0	1	7	7	5	0	0	12	27
09:30 AM	5	4	0	0	9	0	13	0	0	13	11	0	0	0	11	33
09:45 AM	1	1	0	0	2	2	14	0	0	16	11	3	0	0	14	32
Total	16	9	0	0	25	9	47	0	1	57	37	15	0	0	52	134
10:00 AM	6	2	0	0	8	2	14	0	0	16	6	3	0	0	9	33
10:15 AM	6	1	0	0	7	1	13	0	0	14	7	3	0	0	10	31
10:30 AM	7	3	0	0	10	2	12	0	0	14	5	4	0	0	9	33
10:45 AM	4	4	0	0	8	2	10	0	1	13	8	1	0	0	9	30
Total	23	10	0	0	33	7	49	0	1	57	26	11	0	0	37	127
11:00 AM	7	3	0	0	10	1	10	0	0	11	10	2	0	0	12	33
11:15 AM	2	1	0	0	3	2	13	0	0	15	8	1	0	0	9	27
11:30 AM	7	5	0	0	12	6	17	0	0	23	9	6	0	0	15	50
11:45 AM	8	4	0	0	12	1	13	0	0	14	8	4	0	0	12	38
Total	24	13	0	0	37	10	53	0	0	63	35	13	0	0	48	148
12:00 PM	7	2	0	0	9	1	9	0	0	10	10	4	0	0	14	33
12:15 PM	3	4	0	0	7	3	10	0	0	13	12	5	0	0	17	37
12:30 PM	3	1	0	0	4	3	8	0	0	11	9	3	0	0	12	27
12:45 PM	7	3	0	0	10	2	12	0	0	14	10	10	0	0	20	44
Total	20	10	0	0	30	9	39	0	0	48	41	22	0	0	63	141
01:00 PM	3	1	0	0	4	0	12	0	0	12	6	4	0	0	10	26
01:15 PM	3	0	0	0	3	3	8	0	0	11	7	2	0	0	9	23
01:30 PM	5	3	0	0	8	3	13	0	0	16	9	5	0	0	14	38
01:45 PM	5	4	0	0	9	3	9	0	0	12	6	3	0	0	9	30
Total	16	8	0	0	24	9	42	0	0	51	28	14	0	0	42	117
02:00 PM	8	0	0	0	8	2	9	0	0	11	10	1	0	0	11	30
02:15 PM	4	4	0	0	8	2	13	0	0	15	8	4	0	0	12	35
02:30 PM	4	1	0	0	5	1	15	0	0	16	12	1	0	0	13	34
02:45 PM	7	1	0	0	8	6	13	0	0	19	11	3	0	0	14	41
Total	23	6	0	0	29	11	50	0	0	61	41	9	0	0	50	140



TRAFFIC DATA COLLECTION

File Name : Blacksburg(Givens Lane and Carroll Drive)10-19

Site Code :

Start Date : 10/19/2022

Page No : 2

Groups Printed- Cars + - Trucks

Start Time	Carroll Drive Southbound					Givens Lane Westbound					Givens Lane Eastbound					Int. Total
	Right	Left	UTrn	Peds	App. Total	Right	Thru	UTrn	Peds	App. Total	Thru	Left	UTrn	Peds	App. Total	
03:00 PM	7	2	0	0	9	2	14	0	0	16	10	9	0	1	20	45
03:15 PM	2	3	0	0	5	3	15	1	0	19	8	9	0	0	17	41
03:30 PM	8	5	0	0	13	3	16	0	0	19	8	6	0	0	14	46
03:45 PM	7	1	0	0	8	3	9	0	0	12	14	12	0	0	26	46
Total	24	11	0	0	35	11	54	1	0	66	40	36	0	1	77	178
04:00 PM	5	4	0	0	9	3	19	0	1	23	13	8	0	0	21	53
04:15 PM	8	3	0	0	11	5	16	0	0	21	12	9	0	0	21	53
04:30 PM	3	3	0	0	6	8	16	0	0	24	14	5	0	0	19	49
04:45 PM	7	3	0	0	10	3	25	0	0	28	9	6	0	0	15	53
Total	23	13	0	0	36	19	76	0	1	96	48	28	0	0	76	208
05:00 PM	6	2	0	0	8	4	26	0	0	30	16	8	0	0	24	62
05:15 PM	3	5	0	0	8	6	20	0	0	26	9	10	0	0	19	53
05:30 PM	4	2	0	0	6	5	18	0	2	25	13	7	0	0	20	51
05:45 PM	4	4	0	0	8	3	27	0	0	30	11	7	0	0	18	56
Total	17	13	0	0	30	18	91	0	2	111	49	32	0	0	81	222
06:00 PM	7	2	0	0	9	2	8	0	0	10	18	7	0	0	25	44
06:15 PM	2	2	0	0	4	0	11	0	0	11	11	3	0	0	14	29
06:30 PM	6	4	0	0	10	2	21	0	0	23	6	6	0	0	12	45
06:45 PM	2	6	0	0	8	2	20	0	0	22	17	8	0	0	25	55
Total	17	14	0	0	31	6	60	0	0	66	52	24	0	0	76	173
Grand Total	280	125	0	0	405	114	707	1	6	828	451	225	0	3	679	1912
Apprch %	69.1	30.9	0	0		13.8	85.4	0.1	0.7		66.4	33.1	0	0.4		
Total %	14.6	6.5	0	0	21.2	6	37	0.1	0.3	43.3	23.6	11.8	0	0.2	35.5	
Cars +	267	123	0	0	390	112	669	1	6	788	417	217	0	3	637	1815
% Cars +	95.4	98.4	0	0	96.3	98.2	94.6	100	100	95.2	92.5	96.4	0	100	93.8	94.9
Trucks	13	2	0	0	15	2	38	0	0	40	34	8	0	0	42	97
% Trucks	4.6	1.6	0	0	3.7	1.8	5.4	0	0	4.8	7.5	3.6	0	0	6.2	5.1



TRAFFIC DATA COLLECTION

File Name : Blacksburg(Givens Lane and Carroll Drive)10-19
 Site Code :
 Start Date : 10/19/2022
 Page No : 3

Start Time	Carroll Drive Southbound					Givens Lane Westbound					Givens Lane Eastbound					Int. Total
	Right	Left	UTrn	Peds	App. Total	Right	Thru	UTrn	Peds	App. Total	Thru	Left	UTrn	Peds	App. Total	
Peak Hour Analysis From 07:00 AM to 08:45 AM - Peak 1 of 1																
Peak Hour for Entire Intersection Begins at 07:30 AM																
07:30 AM	14	1	0	0	15	1	29	0	1	31	9	5	0	0	14	60
07:45 AM	12	2	0	0	14	2	23	0	0	25	7	2	0	0	9	48
08:00 AM	2	2	0	0	4	0	17	0	0	17	10	3	0	0	13	34
08:15 AM	11	4	0	0	15	0	9	0	0	9	6	3	0	0	9	33
Total Volume	39	9	0	0	48	3	78	0	1	82	32	13	0	0	45	175
% App. Total	81.2	18.8	0	0		3.7	95.1	0	1.2		71.1	28.9	0	0		
PHF	.696	.563	.000	.000	.800	.375	.672	.000	.250	.661	.800	.650	.000	.000	.804	.729

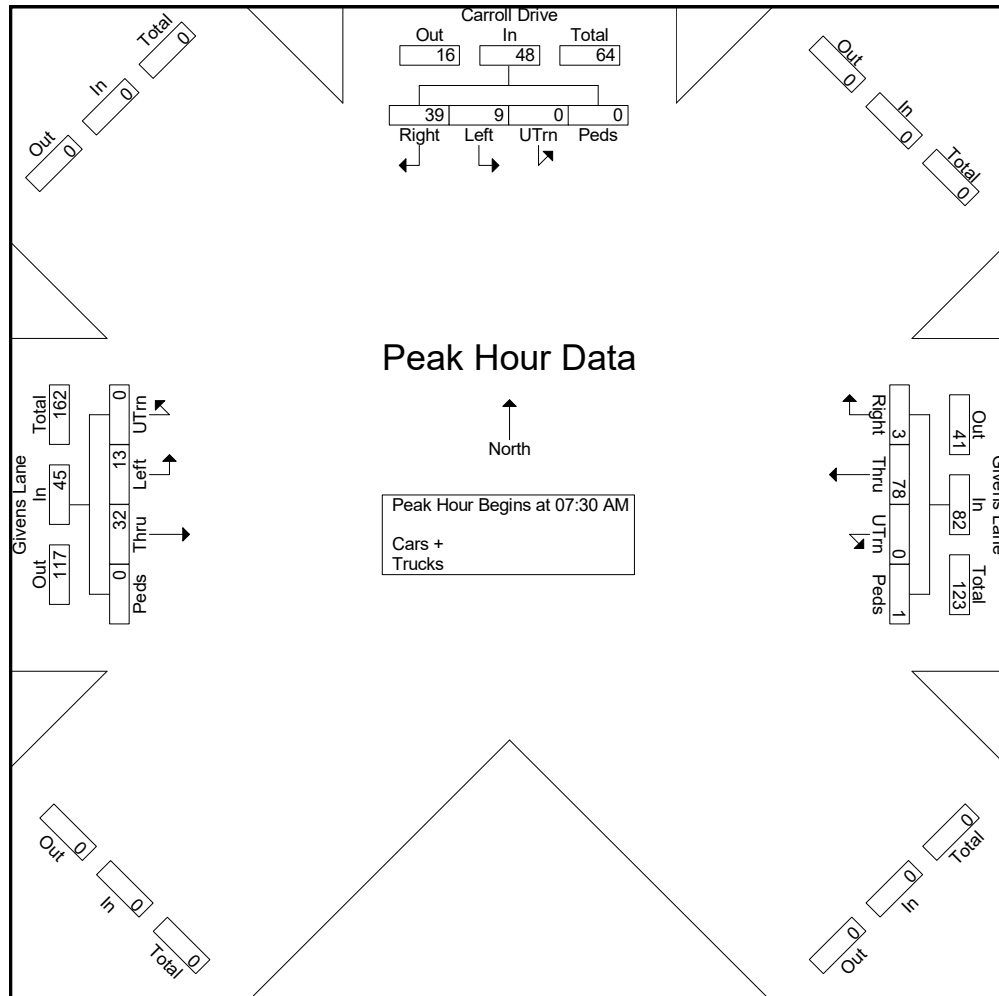



TRAFFIC DATA COLLECTION

File Name : Blacksburg(Givens Lane and Carroll Drive)10-19
 Site Code :
 Start Date : 10/19/2022
 Page No : 4

Start Time	Carroll Drive Southbound					Givens Lane Westbound					Givens Lane Eastbound					Int. Total
	Right	Left	UTrn	Peds	App. Total	Right	Thru	UTrn	Peds	App. Total	Thru	Left	UTrn	Peds	App. Total	
Peak Hour Analysis From 04:00 PM to 05:45 PM - Peak 1 of 1																
Peak Hour for Entire Intersection Begins at 05:00 PM																
05:00 PM	6	2	0	0	8	4	26	0	0	30	16	8	0	0	24	62
05:15 PM	3	5	0	0	8	6	20	0	0	26	9	10	0	0	19	53
05:30 PM	4	2	0	0	6	5	18	0	2	25	13	7	0	0	20	51
05:45 PM	4	4	0	0	8	3	27	0	0	30	11	7	0	0	18	56
Total Volume	17	13	0	0	30	18	91	0	2	111	49	32	0	0	81	222
% App. Total	56.7	43.3	0	0		16.2	82	0	1.8		60.5	39.5	0	0		
PHF	.708	.650	.000	.000	.938	.750	.843	.000	.250	.925	.766	.800	.000	.000	.844	.895

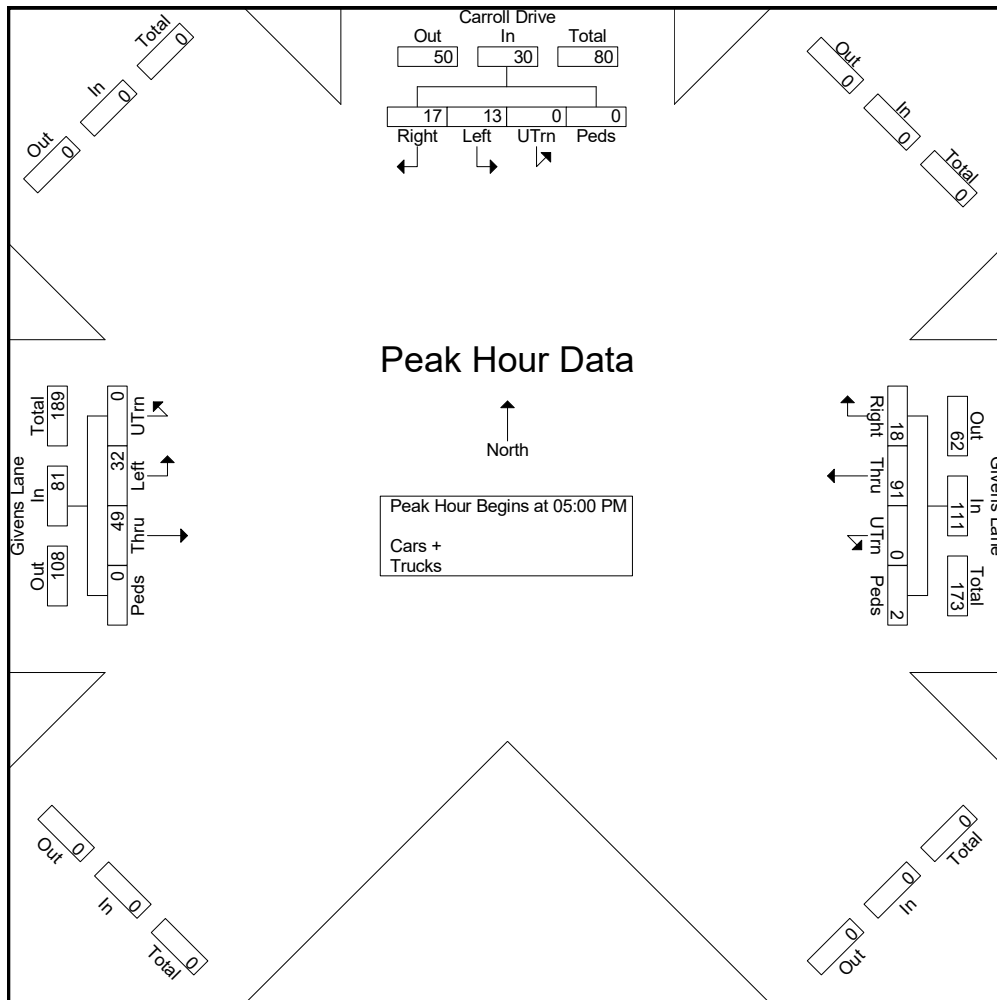



TRAFFIC DATA COLLECTION

File Name : Blacksburg(Givens Lane and Progress Street)
 Site Code :
 Start Date : 10/18/2022
 Page No : 1

Groups Printed- Cars + - Trucks

Start Time	Progress Street Southbound						Givens Lane Westbound						Progress Street Northbound						Givens Lane Eastbound						Int. Total	
	Right	Thru	Left	UTrn	Peds	App. Total	Right	Thru	Left	UTrn	Peds	App. Total	Right	Thru	Left	UTrn	Peds	App. Total	Right	Thru	Left	UTrn	Peds	App. Total		
07:00 AM	0	1	0	0	1	2	0	16	1	1	0	18	0	0	1	0	0	1	0	4	0	0	0	0	4	25
07:15 AM	3	5	0	0	0	8	0	26	5	0	0	31	5	1	1	0	0	7	1	7	1	0	0	9	55	
07:30 AM	8	3	0	1	0	12	0	47	2	0	0	49	2	1	0	0	0	3	0	3	0	0	0	3	67	
07:45 AM	3	1	0	0	1	5	0	32	4	0	0	36	3	0	0	0	0	3	0	3	2	0	0	5	49	
Total	14	10	0	1	2	27	0	121	12	1	0	134	10	2	2	0	0	14	1	17	3	0	0	21	196	
08:00 AM	2	2	0	0	0	4	0	28	3	0	0	31	4	1	2	0	0	7	2	15	3	0	0	20	62	
08:15 AM	3	1	0	0	0	4	0	26	5	0	0	31	1	1	0	0	0	2	1	4	0	0	0	5	42	
08:30 AM	1	5	0	0	0	6	0	31	6	0	0	37	5	1	2	0	1	9	0	5	0	0	0	5	57	
08:45 AM	3	2	0	0	0	5	0	22	12	0	0	34	8	0	0	1	0	9	2	8	1	0	0	11	59	
Total	9	10	0	0	0	19	0	107	26	0	0	133	18	3	4	1	1	27	5	32	4	0	0	41	220	
09:00 AM	1	1	0	0	0	2	0	19	7	0	0	26	5	0	0	0	1	6	0	6	0	0	0	6	40	
09:15 AM	0	3	0	0	0	3	0	15	2	1	0	18	3	1	0	0	0	4	0	12	0	0	0	12	37	
09:30 AM	1	1	0	0	0	2	0	26	2	0	0	28	3	1	2	0	0	6	0	8	0	0	0	8	44	
09:45 AM	1	3	0	0	0	4	0	9	6	0	0	15	2	0	2	0	0	4	0	5	0	0	0	5	28	
Total	3	8	0	0	0	11	0	69	17	1	0	87	13	2	4	0	1	20	0	31	0	0	0	31	149	
10:00 AM	1	0	0	0	0	1	0	16	2	0	0	18	4	0	1	0	1	6	1	6	0	0	0	7	32	
10:15 AM	0	4	0	0	0	4	1	15	4	0	0	20	3	1	0	0	0	4	0	12	0	0	0	12	40	
10:30 AM	1	0	0	0	0	1	0	22	3	0	0	25	4	3	0	0	0	7	0	10	0	0	0	10	43	
10:45 AM	0	2	0	0	0	2	0	8	0	0	0	8	4	1	0	0	0	5	0	9	4	0	0	13	28	
Total	2	6	0	0	0	8	1	61	9	0	0	71	15	5	1	0	1	22	1	37	4	0	0	42	143	
11:00 AM	0	1	0	0	0	1	0	13	4	0	0	17	5	0	0	0	0	5	1	5	0	0	0	6	29	
11:15 AM	1	1	0	0	0	2	0	13	3	0	0	16	3	0	0	0	2	5	1	5	0	0	0	6	29	
11:30 AM	1	1	0	0	0	2	0	12	8	0	0	20	2	1	1	0	0	4	3	9	1	0	0	13	39	
11:45 AM	0	0	0	0	0	0	0	11	3	0	0	14	7	1	0	0	1	9	1	8	0	0	0	9	32	
Total	2	3	0	0	0	5	0	49	18	0	0	67	17	2	1	0	3	23	6	27	1	0	0	34	129	
12:00 PM	1	1	0	0	0	2	0	12	3	0	0	15	6	2	1	0	1	10	1	14	1	0	0	16	43	
12:15 PM	0	0	0	0	0	0	0	12	0	0	0	12	4	1	0	0	1	6	0	10	0	0	0	10	28	
12:30 PM	2	1	0	0	0	3	0	11	2	0	0	13	2	0	1	0	0	3	2	8	1	0	0	11	30	
12:45 PM	0	0	0	0	0	0	0	9	3	0	0	12	2	4	0	0	0	6	2	7	1	0	0	10	28	
Total	3	2	0	0	0	5	0	44	8	0	0	52	14	7	2	0	2	25	5	39	3	0	0	47	129	
01:00 PM	1	0	1	0	0	2	0	19	1	0	0	20	4	0	1	0	0	5	2	11	1	0	0	14	41	
01:15 PM	1	1	2	0	0	4	0	16	4	0	0	20	5	3	0	0	1	9	0	4	0	0	0	4	37	
01:30 PM	2	1	0	0	0	3	0	11	0	0	0	11	1	1	1	0	0	3	1	8	1	0	0	10	27	
01:45 PM	1	0	0	0	0	1	0	11	1	0	0	12	2	1	0	0	0	3	1	8	1	0	0	10	26	
Total	5	2	3	0	0	10	0	57	6	0	0	63	12	5	2	0	1	20	4	31	3	0	0	38	131	



TRAFFIC DATA COLLECTION

File Name : Blacksburg(Givens Lane and Progress Street)

Site Code :

Start Date : 10/18/2022

Page No : 2

Groups Printed- Cars + - Trucks

Start Time	Progress Street Southbound						Givens Lane Westbound						Progress Street Northbound						Givens Lane Eastbound						Int. Total
	Right	Thru	Left	UTrn	Peds	App. Total	Right	Thru	Left	UTrn	Peds	App. Total	Right	Thru	Left	UTrn	Peds	App. Total	Right	Thru	Left	UTrn	Peds	App. Total	
02:00 PM	0	1	0	0	0	1	0	10	0	0	0	10	4	3	2	0	0	9	1	8	0	0	0	9	29
02:15 PM	1	1	0	0	0	2	0	15	1	0	0	16	6	0	0	0	0	6	2	9	2	0	0	13	37
02:30 PM	0	1	1	0	0	2	0	20	1	0	0	21	2	0	1	0	0	3	0	11	0	0	0	11	37
02:45 PM	2	0	0	0	0	2	0	13	5	0	0	18	6	0	1	0	0	7	0	16	2	0	0	18	45
Total	3	3	1	0	0	7	0	58	7	0	0	65	18	3	4	0	0	25	3	44	4	0	0	51	148
03:00 PM	4	0	0	0	0	4	0	15	4	0	0	19	3	2	0	0	0	5	1	19	3	0	0	23	51
03:15 PM	1	1	1	0	1	4	0	18	3	0	0	21	8	0	0	0	1	9	3	16	3	0	0	22	56
03:30 PM	0	0	4	0	0	4	1	11	7	0	0	19	4	1	2	0	0	7	2	12	2	0	0	16	46
03:45 PM	1	1	0	0	0	2	0	16	3	0	0	19	11	1	1	0	0	13	2	12	0	0	0	14	48
Total	6	2	5	0	1	14	1	60	17	0	0	78	26	4	3	0	1	34	8	59	8	0	0	75	201
04:00 PM	0	0	0	0	0	0	1	18	3	0	0	22	7	0	2	0	0	9	2	10	2	0	0	14	45
04:15 PM	2	2	0	0	0	4	0	21	5	0	0	26	4	3	0	0	0	7	3	16	0	0	0	19	56
04:30 PM	1	0	0	0	0	1	0	19	5	0	0	24	3	3	1	0	0	7	0	18	1	1	0	20	52
04:45 PM	4	2	0	0	0	6	0	19	4	0	0	23	7	0	4	0	0	11	2	15	2	0	0	19	59
Total	7	4	0	0	0	11	1	77	17	0	0	95	21	6	7	0	0	34	7	59	5	1	0	72	212
05:00 PM	1	0	1	0	0	2	0	32	4	0	0	36	11	3	1	0	0	15	4	18	2	0	0	24	77
05:15 PM	1	1	0	0	0	2	0	23	1	0	0	24	8	0	2	0	0	10	3	22	0	0	0	25	61
05:30 PM	0	1	1	0	0	2	1	20	7	0	0	28	5	3	2	0	0	10	2	20	6	0	0	28	68
05:45 PM	0	1	0	0	0	1	0	13	5	0	0	18	6	3	0	0	2	11	2	20	5	0	0	27	57
Total	2	3	2	0	0	7	1	88	17	0	0	106	30	9	5	0	2	46	11	80	13	0	0	104	263
06:00 PM	2	3	0	0	0	5	0	30	4	0	0	34	5	2	2	0	0	9	0	14	2	0	0	16	64
06:15 PM	2	0	0	0	0	2	0	22	8	0	0	30	4	2	2	0	1	9	0	16	3	0	0	19	60
06:30 PM	2	1	0	0	0	3	0	14	3	0	0	17	5	1	2	0	0	8	1	15	3	0	0	19	47
06:45 PM	1	0	1	0	0	2	0	15	2	0	0	17	9	0	0	0	0	9	1	18	0	0	2	21	49
Total	7	4	1	0	0	12	0	81	17	0	0	98	23	5	6	0	1	35	2	63	8	0	2	75	220
Grand Total	63	57	12	1	3	136	4	872	171	2	0	1049	217	53	41	1	13	325	53	519	56	1	2	631	2141
Apprch %	46.3	41.9	8.8	0.7	2.2		0.4	83.1	16.3	0.2	0		66.8	16.3	12.6	0.3	4		8.4	82.3	8.9	0.2	0.3		
Total %	2.9	2.7	0.6	0	0.1	6.4	0.2	40.7	8	0.1	0	49	10.1	2.5	1.9	0	0.6	15.2	2.5	24.2	2.6	0	0.1	29.5	
Cars +	62	56	12	1	3	134	4	862	168	2	0	1036	212	53	41	1	12	319	51	511	55	1	2	620	2109
% Cars +	98.4	98.2	100	100	100	98.5	100	98.9	98.2	100	0	98.8	97.7	100	100	100	92.3	98.2	96.2	98.5	98.2	100	100	98.3	98.5
Trucks	1	1	0	0	0	2	0	10	3	0	0	13	5	0	0	0	1	6	2	8	1	0	0	11	32
% Trucks	1.6	1.8	0	0	0	1.5	0	1.1	1.8	0	0	1.2	2.3	0	0	0	7.7	1.8	3.8	1.5	1.8	0	0	1.7	1.5



TRAFFIC DATA COLLECTION

File Name : Blacksburg(Givens Lane and Progress Street)
 Site Code :
 Start Date : 10/18/2022
 Page No : 3

Start Time	Progress Street Southbound						Givens Lane Westbound						Progress Street Northbound						Givens Lane Eastbound						Int. Total
	Right	Thru	Left	UTrn	Peds	App. Total	Right	Thru	Left	UTrn	Peds	App. Total	Right	Thru	Left	UTrn	Peds	App. Total	Right	Thru	Left	UTrn	Peds	App. Total	
Peak Hour Analysis From 07:00 AM to 08:45 AM - Peak 1 of 1																									
Peak Hour for Entire Intersection Begins at 07:15 AM																									
07:15 AM	3	5	0	0	0	8	0	26	5	0	0	31	5	1	1	0	0	7	1	7	1	0	0	9	55
07:30 AM	8	3	0	1	0	12	0	47	2	0	0	49	2	1	0	0	0	3	0	3	0	0	0	3	67
07:45 AM	3	1	0	0	1	5	0	32	4	0	0	36	3	0	0	0	0	3	0	3	2	0	0	5	49
08:00 AM	2	2	0	0	0	4	0	28	3	0	0	31	4	1	2	0	0	7	2	15	3	0	0	20	62
Total Volume	16	11	0	1	1	29	0	133	14	0	0	147	14	3	3	0	0	20	3	28	6	0	0	37	233
% App. Total	55.2	37.9	0	3.4	3.4		0	90.5	9.5	0	0		70	15	15	0	0		8.1	75.7	16.2	0	0		
PHF	.500	.550	.000	.250	.250	.604	.000	.707	.700	.000	.000	.750	.700	.750	.375	.000	.000	.714	.375	.467	.500	.000	.000	.463	.869

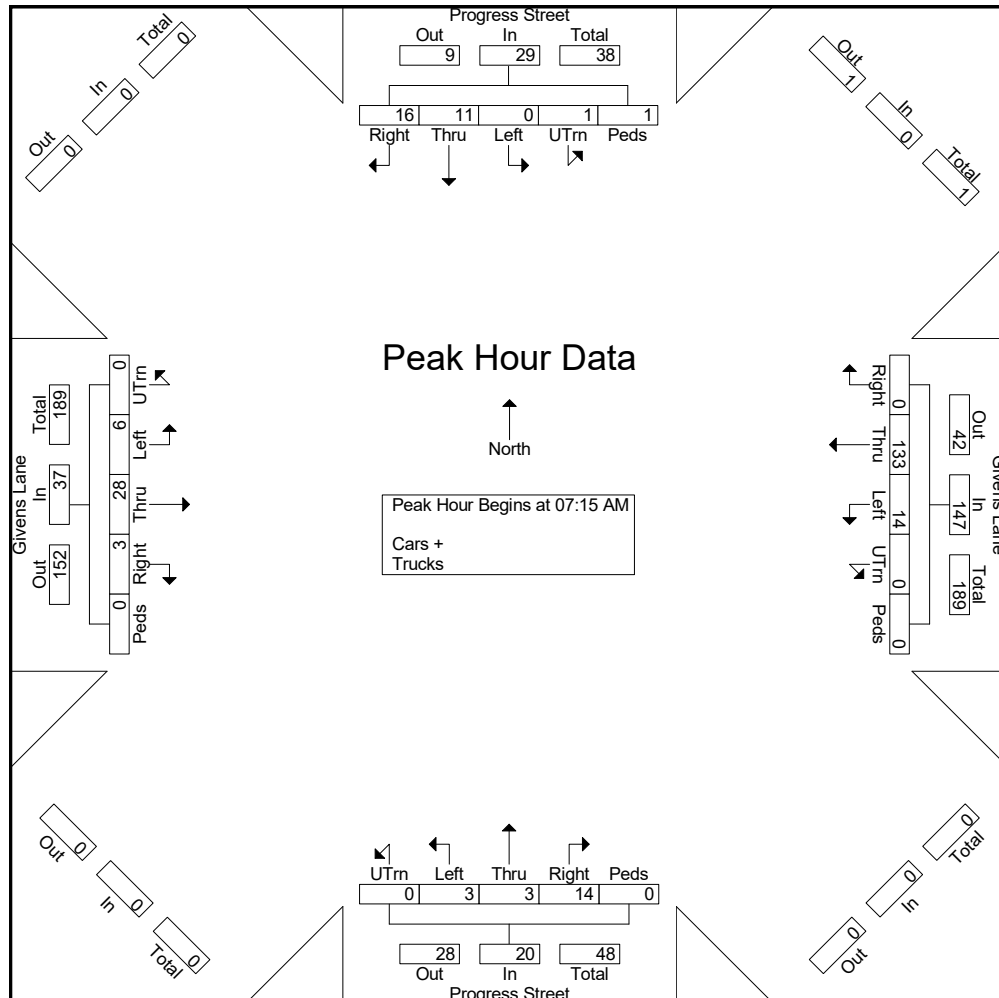



TRAFFIC DATA COLLECTION

File Name : Blacksburg(Givens Lane and Progress Street)
 Site Code :
 Start Date : 10/18/2022
 Page No : 4

Start Time	Progress Street Southbound						Givens Lane Westbound						Progress Street Northbound						Givens Lane Eastbound						Int. Total
	Right	Thru	Left	UTrn	Peds	App. Total	Right	Thru	Left	UTrn	Peds	App. Total	Right	Thru	Left	UTrn	Peds	App. Total	Right	Thru	Left	UTrn	Peds	App. Total	
Peak Hour Analysis From 04:00 PM to 05:45 PM - Peak 1 of 1																									
Peak Hour for Entire Intersection Begins at 04:45 PM																									
04:45 PM	4	2	0	0	0	6	0	19	4	0	0	23	7	0	4	0	0	11	2	15	2	0	0	19	59
05:00 PM	1	0	1	0	0	2	0	32	4	0	0	36	11	3	1	0	0	15	4	18	2	0	0	24	77
05:15 PM	1	1	0	0	0	2	0	23	1	0	0	24	8	0	2	0	0	10	3	22	0	0	0	25	61
05:30 PM	0	1	1	0	0	2	1	20	7	0	0	28	5	3	2	0	0	10	2	20	6	0	0	28	68
Total Volume	6	4	2	0	0	12	1	94	16	0	0	111	31	6	9	0	0	46	11	75	10	0	0	96	265
% App. Total	50	33.3	16.7	0	0		0.9	84.7	14.4	0	0		67.4	13	19.6	0	0		11.5	78.1	10.4	0	0		
PHF	.375	.500	.500	.000	.000	.500	.250	.734	.571	.000	.000	.771	.705	.500	.563	.000	.000	.767	.688	.852	.417	.000	.000	.857	.860

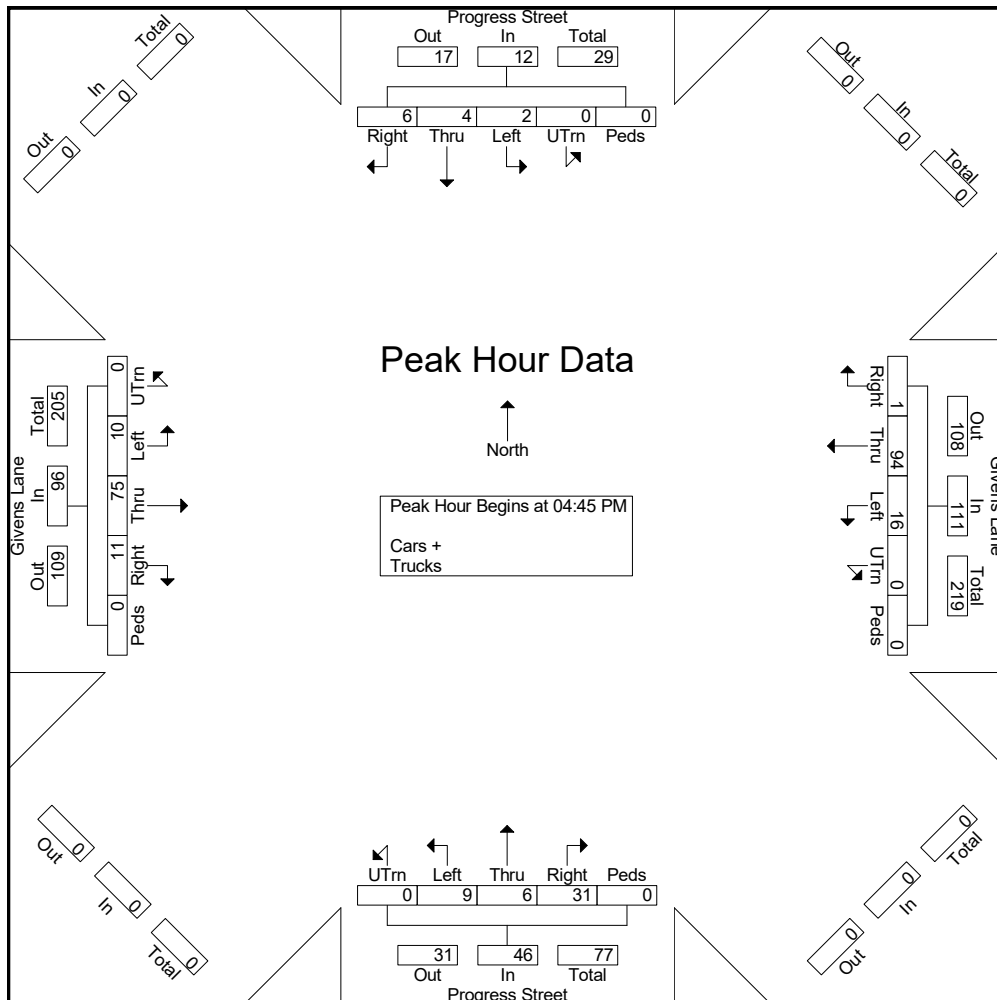



TRAFFIC DATA COLLECTION

File Name : Blacksburg(Givens Lane and Progress Street)
 Site Code :
 Start Date : 10/19/2022
 Page No : 1

Groups Printed- Cars + - Trucks

Start Time	Progress Street Southbound						Givens Lane Westbound						Progress Street Northbound						Givens Lane Eastbound						Int. Total	
	Right	Thru	Left	UTrn	Peds	App. Total	Right	Thru	Left	UTrn	Peds	App. Total	Right	Thru	Left	UTrn	Peds	App. Total	Right	Thru	Left	UTrn	Peds	App. Total		
07:00 AM	1	0	0	0	0	1	1	14	1	0	0	16	0	2	0	0	0	2	0	2	0	0	0	0	2	21
07:15 AM	3	4	0	0	0	7	0	25	3	0	0	28	3	1	1	1	0	6	2	3	1	0	0	6	47	
07:30 AM	6	4	0	0	1	11	0	42	3	0	0	45	1	1	0	0	0	2	0	6	0	0	0	6	64	
07:45 AM	4	2	1	0	0	7	0	36	4	0	0	40	0	0	1	0	0	1	0	7	2	0	0	9	57	
Total	14	10	1	0	1	26	1	117	11	0	0	129	4	4	2	1	0	11	2	18	3	0	0	23	189	
08:00 AM	4	0	0	0	0	4	0	20	4	0	0	24	3	0	0	0	0	3	0	12	1	0	0	13	44	
08:15 AM	0	3	0	0	0	3	1	20	4	0	0	25	0	2	0	0	1	3	1	6	0	0	0	7	38	
08:30 AM	3	2	0	0	0	5	0	32	7	0	0	39	0	0	1	1	0	2	2	5	2	0	0	9	55	
08:45 AM	1	3	0	0	0	4	0	31	8	0	0	39	4	0	0	0	3	7	1	7	0	0	0	8	58	
Total	8	8	0	0	0	16	1	103	23	0	0	127	7	2	1	1	4	15	4	30	3	0	0	37	195	
09:00 AM	3	4	0	0	0	7	0	21	5	0	0	26	8	1	1	0	2	12	1	4	2	0	0	7	52	
09:15 AM	3	2	0	0	0	5	1	11	4	0	0	16	1	1	0	0	0	2	0	6	2	0	0	8	31	
09:30 AM	1	1	0	0	0	2	1	18	4	0	0	23	4	0	0	0	0	4	1	7	2	0	0	10	39	
09:45 AM	1	1	1	0	0	3	0	18	2	0	0	20	4	1	3	0	1	9	0	5	0	0	0	5	37	
Total	8	8	1	0	0	17	2	68	15	0	0	85	17	3	4	0	3	27	2	22	6	0	0	30	159	
10:00 AM	1	0	0	0	0	1	0	16	3	0	0	19	3	0	1	0	0	4	1	5	0	0	0	6	30	
10:15 AM	0	0	0	0	0	0	0	13	3	0	0	16	3	2	1	0	0	6	0	8	1	0	0	9	31	
10:30 AM	0	1	1	0	0	2	0	18	1	0	0	19	4	0	1	0	0	5	1	9	2	0	0	12	38	
10:45 AM	0	1	0	0	0	1	0	11	3	0	0	14	2	0	2	0	0	4	3	8	0	0	0	11	30	
Total	1	2	1	0	0	4	0	58	10	0	0	68	12	2	5	0	0	19	5	30	3	0	0	38	129	
11:00 AM	2	0	0	0	0	2	0	14	2	0	0	16	2	0	2	0	0	4	0	12	1	0	0	13	35	
11:15 AM	0	0	0	0	0	0	0	13	2	0	0	15	2	0	0	0	0	2	0	8	0	0	0	8	25	
11:30 AM	1	1	0	0	0	2	0	20	6	0	0	26	4	1	0	0	0	5	2	13	0	1	0	16	49	
11:45 AM	0	2	0	0	1	3	1	15	6	0	0	22	6	1	0	0	0	7	1	6	4	0	0	11	43	
Total	3	3	0	0	1	7	1	62	16	0	0	79	14	2	2	0	0	18	3	39	5	1	0	48	152	
12:00 PM	0	1	0	0	0	1	0	10	4	0	0	14	6	2	0	0	0	8	1	5	0	0	0	6	29	
12:15 PM	3	1	0	0	0	4	0	12	3	0	0	15	7	2	0	0	0	9	2	17	1	0	0	20	48	
12:30 PM	1	0	0	0	0	1	0	13	2	0	0	15	3	0	0	0	0	3	3	8	0	0	0	11	30	
12:45 PM	0	1	0	0	0	1	0	16	4	0	0	20	6	1	0	0	0	7	1	9	0	0	0	10	38	
Total	4	3	0	0	0	7	0	51	13	0	0	64	22	5	0	0	0	27	7	39	1	0	0	47	145	
01:00 PM	1	1	0	0	0	2	0	15	4	0	0	19	3	1	1	0	0	5	2	7	2	0	0	11	37	
01:15 PM	2	1	0	0	0	3	0	8	4	0	0	12	0	0	0	0	0	0	0	8	1	0	0	9	24	
01:30 PM	3	0	1	0	0	4	0	15	3	0	0	18	7	1	2	0	0	10	1	12	1	0	0	14	46	
01:45 PM	1	2	0	0	0	3	1	14	4	0	0	19	5	1	1	0	0	7	1	8	1	0	0	10	39	
Total	7	4	1	0	0	12	1	52	15	0	0	68	15	3	4	0	0	22	4	35	5	0	0	44	146	



TRAFFIC DATA COLLECTION

File Name : Blacksburg(Givens Lane and Progress Street)

Site Code :

Start Date : 10/19/2022

Page No : 2

Groups Printed- Cars + - Trucks

Start Time	Progress Street Southbound						Givens Lane Westbound						Progress Street Northbound						Givens Lane Eastbound						Int. Total
	Right	Thru	Left	UTrn	Peds	App. Total	Right	Thru	Left	UTrn	Peds	App. Total	Right	Thru	Left	UTrn	Peds	App. Total	Right	Thru	Left	UTrn	Peds	App. Total	
02:00 PM	2	0	0	0	0	2	0	18	5	0	0	23	6	0	4	0	0	10	1	7	1	0	0	9	44
02:15 PM	1	0	0	0	0	1	0	16	3	0	0	19	1	0	2	0	0	3	0	10	1	0	0	11	34
02:30 PM	0	0	0	0	0	0	0	18	2	0	0	20	1	1	1	0	0	3	0	10	5	0	0	15	38
02:45 PM	1	1	1	0	0	3	0	16	6	0	0	22	2	2	0	0	0	4	1	14	0	0	0	15	44
Total	4	1	1	0	0	6	0	68	16	0	0	84	10	3	7	0	0	20	2	41	7	0	0	50	160
03:00 PM	1	1	3	0	0	5	1	21	2	0	0	24	1	2	1	0	0	4	2	17	2	0	0	21	54
03:15 PM	2	2	1	0	0	5	1	12	0	0	0	13	6	0	1	0	0	7	2	11	4	0	0	17	42
03:30 PM	0	1	0	0	0	1	0	21	8	0	0	29	5	2	1	0	1	9	0	12	0	0	0	12	51
03:45 PM	2	1	0	0	0	3	0	10	7	0	0	17	12	1	1	0	0	14	3	24	2	0	0	29	63
Total	5	5	4	0	0	14	2	64	17	0	0	83	24	5	4	0	1	34	7	64	8	0	0	79	210
04:00 PM	0	2	0	0	0	2	0	17	2	0	0	19	6	2	2	0	0	10	2	13	0	0	0	15	46
04:15 PM	0	1	0	0	0	1	0	26	2	0	0	28	10	2	2	0	2	16	3	23	2	0	0	28	73
04:30 PM	0	1	0	0	0	1	1	11	5	0	0	17	5	0	1	0	0	6	1	16	1	0	0	18	42
04:45 PM	1	2	0	0	0	3	0	27	9	0	0	36	4	3	2	0	0	9	3	11	3	0	0	17	65
Total	1	6	0	0	0	7	1	81	18	0	0	100	25	7	7	0	2	41	9	63	6	0	0	78	226
05:00 PM	3	1	0	0	0	4	0	29	6	0	0	35	9	6	0	0	0	15	1	18	3	0	0	22	76
05:15 PM	4	1	1	0	0	6	0	21	5	0	0	26	6	3	2	0	0	11	1	21	1	0	0	23	66
05:30 PM	1	0	0	0	1	2	0	13	8	0	0	21	5	1	1	0	1	8	3	10	3	0	0	16	47
05:45 PM	2	2	0	0	2	6	0	21	6	0	0	27	5	3	1	0	2	11	5	22	3	0	0	30	74
Total	10	4	1	0	3	18	0	84	25	0	0	109	25	13	4	0	3	45	10	71	10	0	0	91	263
06:00 PM	4	2	0	0	0	6	0	13	3	0	0	16	5	6	1	0	0	12	4	23	0	0	0	27	61
06:15 PM	1	0	0	0	0	1	1	9	1	0	0	11	5	1	3	0	3	12	3	15	3	0	0	21	45
06:30 PM	4	2	1	0	1	8	1	26	2	0	0	29	7	0	1	0	0	8	4	13	2	1	0	20	65
06:45 PM	0	0	0	0	0	0	0	16	6	0	0	22	10	1	1	0	1	13	0	18	0	0	0	18	53
Total	9	4	1	0	1	15	2	64	12	0	0	78	27	8	6	0	4	45	11	69	5	1	0	86	224
Grand Total	74	58	11	0	6	149	11	872	191	0	0	1074	202	57	46	2	17	324	66	521	62	2	0	651	2198
Apprch %	49.7	38.9	7.4	0	4		1	81.2	17.8	0	0		62.3	17.6	14.2	0.6	5.2		10.1	80	9.5	0.3	0		
Total %	3.4	2.6	0.5	0	0.3	6.8	0.5	39.7	8.7	0	0	48.9	9.2	2.6	2.1	0.1	0.8	14.7	3	23.7	2.8	0.1	0	29.6	
Cars +	73	57	11	0	6	147	10	851	187	0	0	1048	197	56	46	2	17	318	64	509	61	2	0	636	2149
% Cars +	98.6	98.3	100	0	100	98.7	90.9	97.6	97.9	0	0	97.6	97.5	98.2	100	100	100	98.1	97	97.7	98.4	100	0	97.7	97.8
Trucks	1	1	0	0	0	2	1	21	4	0	0	26	5	1	0	0	0	6	2	12	1	0	0	15	49
% Trucks	1.4	1.7	0	0	0	1.3	9.1	2.4	2.1	0	0	2.4	2.5	1.8	0	0	0	1.9	3	2.3	1.6	0	0	2.3	2.2



TRAFFIC DATA COLLECTION

File Name : Blacksburg(Givens Lane and Progress Street)
 Site Code :
 Start Date : 10/19/2022
 Page No : 3

Start Time	Progress Street Southbound						Givens Lane Westbound						Progress Street Northbound						Givens Lane Eastbound						Int. Total
	Right	Thru	Left	UTrn	Peds	App. Total	Right	Thru	Left	UTrn	Peds	App. Total	Right	Thru	Left	UTrn	Peds	App. Total	Right	Thru	Left	UTrn	Peds	App. Total	
Peak Hour Analysis From 07:00 AM to 08:45 AM - Peak 1 of 1																									
Peak Hour for Entire Intersection Begins at 07:15 AM																									
07:15 AM	3	4	0	0	0	7	0	25	3	0	0	28	3	1	1	1	0	6	2	3	1	0	0	6	47
07:30 AM	6	4	0	0	1	11	0	42	3	0	0	45	1	1	0	0	0	2	0	6	0	0	0	6	64
07:45 AM	4	2	1	0	0	7	0	36	4	0	0	40	0	0	1	0	0	1	0	7	2	0	0	9	57
08:00 AM	4	0	0	0	0	4	0	20	4	0	0	24	3	0	0	0	0	3	0	12	1	0	0	13	44
Total Volume	17	10	1	0	1	29	0	123	14	0	0	137	7	2	2	1	0	12	2	28	4	0	0	34	212
% App. Total	58.6	34.5	3.4	0	3.4		0	89.8	10.2	0	0		58.3	16.7	16.7	8.3	0		5.9	82.4	11.8	0	0		
PHF	.708	.625	.250	.000	.250	.659	.000	.732	.875	.000	.000	.761	.583	.500	.500	.250	.000	.500	.250	.583	.500	.000	.000	.654	.828

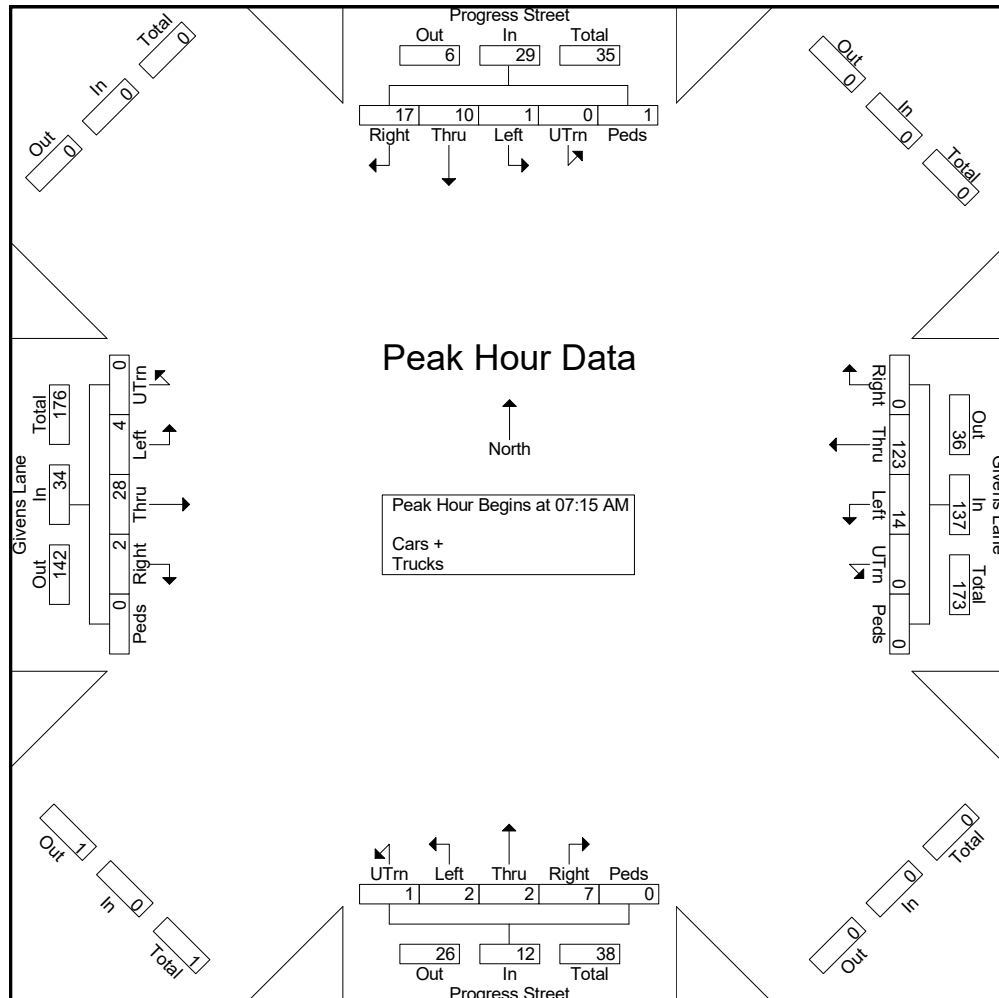



TRAFFIC DATA COLLECTION

File Name : Blacksburg(Givens Lane and Progress Street)
 Site Code :
 Start Date : 10/19/2022
 Page No : 4

Start Time	Progress Street Southbound						Givens Lane Westbound						Progress Street Northbound						Givens Lane Eastbound						Int. Total		
	Right	Thru	Left	UTrn	Peds	App. Total	Right	Thru	Left	UTrn	Peds	App. Total	Right	Thru	Left	UTrn	Peds	App. Total	Right	Thru	Left	UTrn	Peds	App. Total			
Peak Hour Analysis From 04:00 PM to 05:45 PM - Peak 1 of 1																											
Peak Hour for Entire Intersection Begins at 05:00 PM																											
05:00 PM	3	1	0	0	0	4	0	29	6	0	0	35	9	6	0	0	0	15	1	18	3	0	0	22	76		
05:15 PM	4	1	1	0	0	6	0	21	5	0	0	26	6	3	2	0	0	11	1	21	1	0	0	23	66		
05:30 PM	1	0	0	0	1	2	0	13	8	0	0	21	5	1	1	0	1	8	3	10	3	0	0	16	47		
05:45 PM	2	2	0	0	2	6	0	21	6	0	0	27	5	3	1	0	2	11	5	22	3	0	0	30	74		
Total Volume	10	4	1	0	3	18	0	84	25	0	0	109	25	13	4	0	3	45	10	71	10	0	0	91	263		
% App. Total	55.6	22.2	5.6	0	16.7	0	77.1	22.9	0	0	55.6	28.9	8.9	0	6.7	11	78	11	0	0							
PHF	.625	.500	.250	.000	.375	.750	.000	.724	.781	.000	.000	.779	.694	.542	.500	.000	.375	.750	.500	.807	.833	.000	.000	.758	.865		

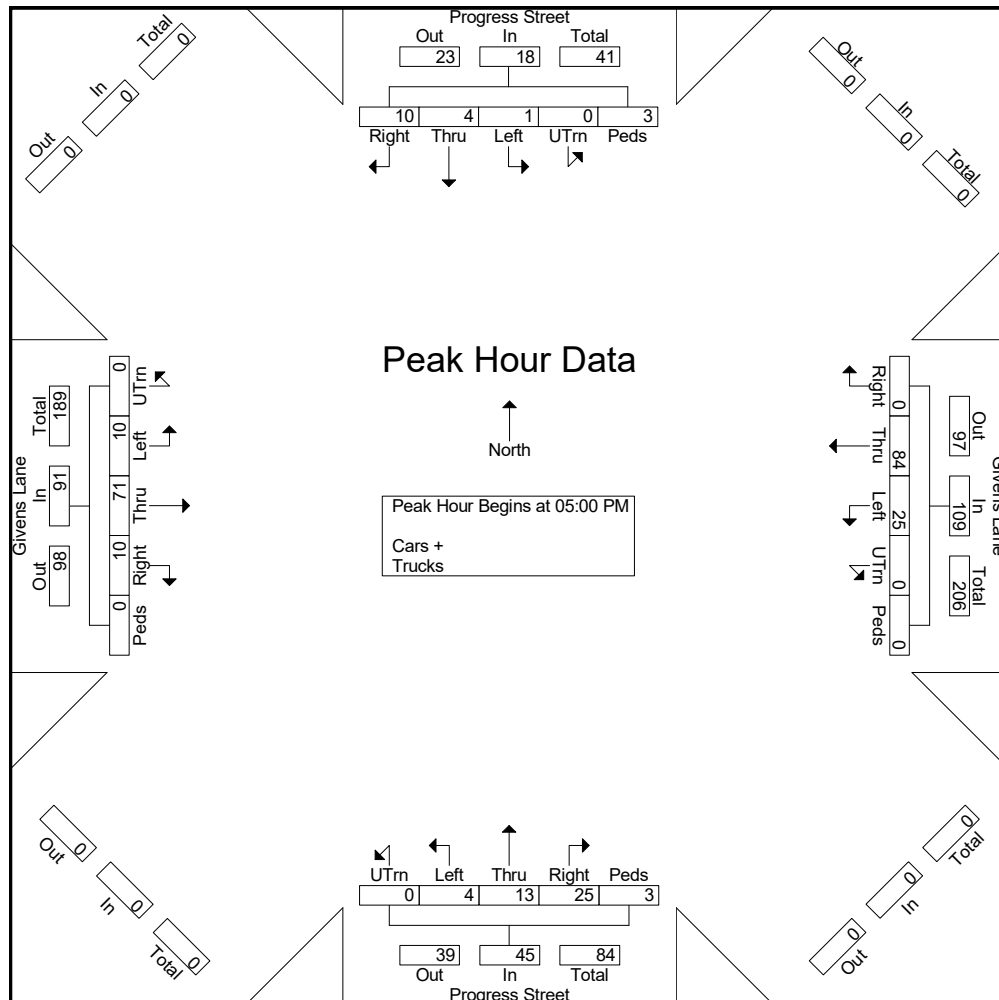



TRAFFIC DATA COLLECTION

File Name : Blacksburg(Main and Givens) Day 1

Site Code :

Start Date : 4/12/2022

Page No : 2

Groups Printed- Trucks

Start Time	N Main Street Southbound		Mountain Breeze Drive Westbound		N Main Street Northbound		Givens Lane Eastbound		Int. Total
	Bikes	App. Total	Bikes	App. Total	Bikes	App. Total	Bikes	App. Total	
02:45 PM	0	0	0	0	0	0	0	0	0
Total	0	0	1	1	0	0	0	0	1
03:00 PM	0	0	0	0	0	0	0	0	0
03:15 PM	0	0	0	0	0	0	0	0	0
03:30 PM	0	0	0	0	0	0	0	0	0
03:45 PM	0	0	0	0	0	0	0	0	0
Total	0	0	0	0	0	0	0	0	0
04:00 PM	0	0	0	0	0	0	0	0	0
04:15 PM	0	0	0	0	0	0	0	0	0
04:30 PM	0	0	0	0	0	0	0	0	0
04:45 PM	0	0	0	0	0	0	0	0	0
Total	0	0	0	0	0	0	0	0	0
05:00 PM	0	0	0	0	0	0	0	0	0
05:15 PM	0	0	0	0	0	0	0	0	0
05:30 PM	0	0	0	0	0	0	0	0	0
05:45 PM	0	0	0	0	0	0	0	0	0
Total	0	0	0	0	0	0	0	0	0
06:00 PM	0	0	0	0	0	0	0	0	0
06:15 PM	0	0	0	0	0	0	0	0	0
06:30 PM	0	0	0	0	0	0	0	0	0
06:45 PM	0	0	0	0	0	0	0	0	0
Total	0	0	0	0	0	0	0	0	0
Grand Total	1	1	1	1	0	0	0	0	2
Apprch %	100		100		0		0		
Total %	50	50	50	50	0	0	0	0	



TRAFFIC DATA COLLECTION

File Name : Blacksburg(Main and Givens) Day 1

Site Code :

Start Date : 4/12/2022

Page No : 3

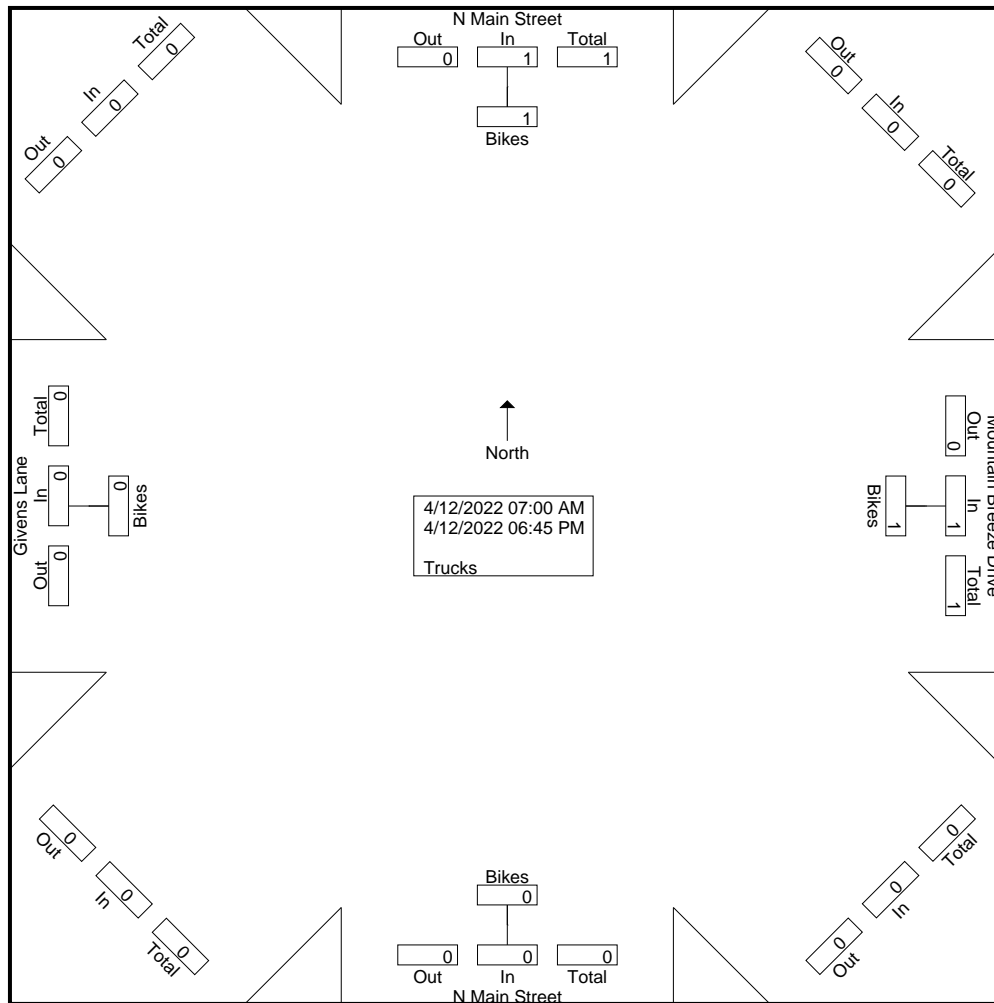



TRAFFIC DATA COLLECTION

File Name : Blacksburg(Main and Givens) Day 1
 Site Code :
 Start Date : 4/12/2022
 Page No : 1

Groups Printed- Cars +

Start Time	N Main Street Southbound		Mountain Breeze Drive Westbound		N Main Street Northbound		Givens Lane Eastbound		Int. Total
	Peds	App. Total	Peds	App. Total	Peds	App. Total	Peds	App. Total	
07:00 AM	0	0	0	0	0	0	0	0	0
07:15 AM	0	0	3	3	0	0	0	0	3
07:30 AM	0	0	0	0	0	0	0	0	0
07:45 AM	0	0	0	0	0	0	0	0	0
Total	0	0	3	3	0	0	0	0	3
08:00 AM	0	0	1	1	0	0	0	0	1
08:15 AM	1	1	1	1	0	0	0	0	2
08:30 AM	2	2	0	0	0	0	0	0	2
08:45 AM	2	2	0	0	0	0	0	0	2
Total	5	5	2	2	0	0	0	0	7
09:00 AM	2	2	0	0	0	0	0	0	2
09:15 AM	0	0	0	0	0	0	0	0	0
09:30 AM	0	0	0	0	0	0	0	0	0
09:45 AM	1	1	4	4	0	0	0	0	5
Total	3	3	4	4	0	0	0	0	7
10:00 AM	0	0	0	0	0	0	0	0	0
10:15 AM	0	0	1	1	1	1	0	0	2
10:30 AM	0	0	0	0	0	0	0	0	0
10:45 AM	1	1	0	0	0	0	0	0	1
Total	1	1	1	1	1	1	0	0	3
11:00 AM	0	0	0	0	0	0	0	0	0
11:15 AM	0	0	1	1	0	0	0	0	1
11:30 AM	0	0	0	0	1	1	0	0	1
11:45 AM	1	1	1	1	0	0	0	0	2
Total	1	1	2	2	1	1	0	0	4
12:00 PM	0	0	0	0	0	0	1	1	1
12:15 PM	2	2	0	0	0	0	0	0	2
12:30 PM	0	0	3	3	0	0	0	0	3
12:45 PM	2	2	0	0	2	2	0	0	4
Total	4	4	3	3	2	2	1	1	10
01:00 PM	0	0	1	1	0	0	1	1	2
01:15 PM	0	0	2	2	0	0	0	0	2
01:30 PM	1	1	0	0	0	0	0	0	1
01:45 PM	0	0	0	0	0	0	0	0	0
Total	1	1	3	3	0	0	1	1	5
02:00 PM	0	0	0	0	0	0	0	0	0
02:15 PM	1	1	0	0	0	0	0	0	1
02:30 PM	2	2	0	0	0	0	1	1	3



TRAFFIC DATA COLLECTION

File Name : Blacksburg(Main and Givens) Day 1

Site Code :

Start Date : 4/12/2022

Page No : 2

Groups Printed- Cars +

Start Time	N Main Street Southbound		Mountain Breeze Drive Westbound		N Main Street Northbound		Givens Lane Eastbound		Int. Total
	Peds	App. Total	Peds	App. Total	Peds	App. Total	Peds	App. Total	
02:45 PM	0	0	0	0	0	0	0	0	0
Total	3	3	0	0	0	0	1	1	4
03:00 PM	1	1	3	3	1	1	0	0	5
03:15 PM	0	0	1	1	0	0	0	0	1
03:30 PM	2	2	1	1	0	0	3	3	6
03:45 PM	1	1	0	0	0	0	0	0	1
Total	4	4	5	5	1	1	3	3	13
04:00 PM	1	1	1	1	1	1	1	1	4
04:15 PM	0	0	1	1	0	0	0	0	1
04:30 PM	0	0	0	0	0	0	0	0	0
04:45 PM	1	1	0	0	1	1	1	1	3
Total	2	2	2	2	2	2	2	2	8
05:00 PM	0	0	1	1	0	0	0	0	1
05:15 PM	1	1	2	2	0	0	0	0	3
05:30 PM	1	1	0	0	0	0	2	2	3
05:45 PM	3	3	2	2	0	0	0	0	5
Total	5	5	5	5	0	0	2	2	12
06:00 PM	0	0	1	1	0	0	0	0	1
06:15 PM	1	1	2	2	0	0	0	0	3
06:30 PM	0	0	0	0	0	0	0	0	0
06:45 PM	1	1	0	0	1	1	0	0	2
Total	2	2	3	3	1	1	0	0	6
Grand Total	31	31	33	33	8	8	10	10	82
Apprch %	100		100		100		100		
Total %	37.8	37.8	40.2	40.2	9.8	9.8	12.2	12.2	



TRAFFIC DATA COLLECTION

File Name : Blacksburg(Main and Givens) Day 1

Site Code :

Start Date : 4/12/2022

Page No : 3

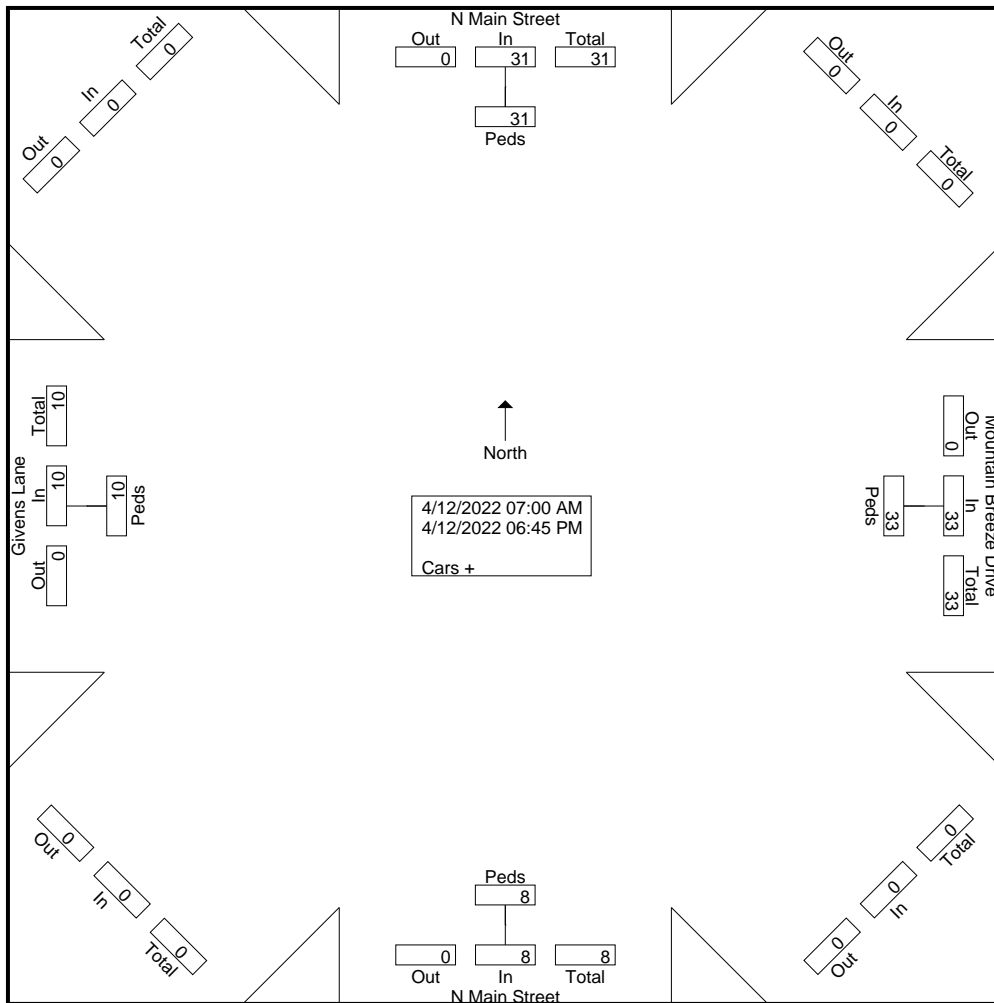



TRAFFIC DATA COLLECTION

File Name : Blacksburg(Main and Givens) Day 1

Site Code :

Start Date : 4/12/2022

Page No : 1

Groups Printed- Cars + - Trucks

Start Time	N Main Street Southbound						Mountain Breeze Drive Westbound						N Main Street Northbound						Givens Lane Eastbound						Int. Total
	Right	Thru	Left	UTrn	Peds	App. Total	Right	Thru	Left	UTrn	Peds	App. Total	Right	Thru	Left	UTrn	Peds	App. Total	Right	Thru	Left	UTrn	Peds	App. Total	
07:00 AM	6	55	1	0	0	62	0	0	1	0	0	1	3	11	2	0	0	16	0	1	1	0	0	2	81
07:15 AM	7	97	1	0	0	105	2	4	3	0	3	12	2	11	2	0	0	15	1	0	0	0	0	1	133
07:30 AM	9	112	2	0	0	123	0	7	8	0	0	15	1	14	3	0	0	18	5	0	5	0	0	10	166
07:45 AM	8	124	2	0	0	134	3	4	8	0	0	15	1	17	3	0	0	21	2	0	0	0	0	2	172
Total	30	388	6	0	0	424	5	15	20	0	3	43	7	53	10	0	0	70	8	1	6	0	0	15	552
08:00 AM	9	78	3	0	0	90	0	2	0	0	1	3	2	33	2	0	0	37	1	0	1	0	0	2	132
08:15 AM	6	78	0	0	1	85	0	2	0	0	1	3	0	33	2	0	0	35	0	0	3	0	0	3	126
08:30 AM	12	132	3	0	2	149	1	3	2	0	0	6	0	23	3	0	0	26	3	0	2	0	0	5	186
08:45 AM	12	119	0	0	2	133	4	3	3	0	0	10	1	46	4	0	0	51	3	1	3	0	0	7	201
Total	39	407	6	0	5	457	5	10	5	0	2	22	3	135	11	0	0	149	7	1	9	0	0	17	645
09:00 AM	5	92	4	0	3	104	0	1	3	0	0	4	1	46	4	0	0	51	1	0	4	0	0	5	164
09:15 AM	8	79	2	0	0	89	1	2	3	0	0	6	4	35	1	0	0	40	1	0	1	0	0	2	137
09:30 AM	5	52	0	0	0	57	0	0	0	0	0	0	1	33	4	0	0	38	1	0	7	0	0	8	103
09:45 AM	1	58	3	0	1	63	0	2	3	0	4	9	1	29	2	0	0	32	3	0	0	0	0	3	107
Total	19	281	9	0	4	313	1	5	9	0	4	19	7	143	11	0	0	161	6	0	12	0	0	18	511
10:00 AM	8	47	0	0	0	55	1	2	2	0	0	5	0	36	6	0	0	42	3	0	2	0	0	5	107
10:15 AM	2	44	1	1	0	48	0	1	0	0	1	2	1	29	2	0	1	33	0	0	2	0	0	2	85
10:30 AM	3	60	1	0	0	64	1	0	2	0	0	3	1	34	2	1	0	38	2	1	3	0	0	6	111
10:45 AM	4	59	0	0	1	64	1	0	0	0	0	1	1	35	6	0	0	42	2	0	0	0	0	2	109
Total	17	210	2	1	1	231	3	3	4	0	1	11	3	134	16	1	1	155	7	1	7	0	0	15	412
11:00 AM	2	53	1	0	0	56	1	0	0	0	0	1	0	55	2	0	0	57	0	0	0	0	0	0	114
11:15 AM	12	65	1	0	0	78	1	1	1	0	1	4	1	44	4	0	0	49	0	1	2	0	0	3	134
11:30 AM	8	62	2	0	0	72	2	1	2	0	0	5	4	45	4	0	1	54	3	0	3	0	0	6	137
11:45 AM	3	45	2	0	1	51	0	1	3	0	1	5	3	51	5	0	0	59	2	0	4	0	0	6	121
Total	25	225	6	0	1	257	4	3	6	0	2	15	8	195	15	0	1	219	5	1	9	0	0	15	506
12:00 PM	7	81	0	0	0	88	0	1	1	0	0	2	2	43	2	0	0	47	2	0	0	0	1	3	140
12:15 PM	6	46	0	0	2	54	1	2	0	0	0	3	2	52	6	0	0	60	1	0	1	0	0	2	119
12:30 PM	6	51	0	0	0	57	2	0	3	0	3	8	0	49	5	0	0	54	2	1	3	0	0	6	125
12:45 PM	2	69	1	0	2	74	0	0	4	0	0	4	3	55	3	0	2	63	1	0	1	0	0	2	143
Total	21	247	1	0	4	273	3	3	8	0	3	17	7	199	16	0	2	224	6	1	5	0	1	13	527
01:00 PM	7	64	0	0	0	71	3	0	2	0	1	6	5	46	1	0	0	52	0	1	3	0	1	5	134
01:15 PM	3	65	0	0	0	68	0	0	0	0	2	2	2	43	4	0	0	49	0	0	4	0	0	4	123
01:30 PM	5	51	2	0	1	59	0	2	4	0	0	6	2	47	2	0	0	51	3	1	2	0	0	6	122
01:45 PM	5	47	0	0	0	52	0	2	1	0	0	3	1	44	2	0	0	47	1	0	3	0	0	4	106
Total	20	227	2	0	1	250	3	4	7	0	3	17	10	180	9	0	0	199	4	2	12	0	1	19	485



TRAFFIC DATA COLLECTION

File Name : Blacksburg(Main and Givens) Day 1
 Site Code :
 Start Date : 4/12/2022
 Page No : 2

Groups Printed- Cars + - Trucks

Start Time	N Main Street Southbound						Mountain Breeze Drive Westbound						N Main Street Northbound						Givens Lane Eastbound						Int. Total
	Right	Thru	Left	UTrn	Peds	App. Total	Right	Thru	Left	UTrn	Peds	App. Total	Right	Thru	Left	UTrn	Peds	App. Total	Right	Thru	Left	UTrn	Peds	App. Total	
02:00 PM	9	39	2	0	0	50	0	4	1	0	0	5	3	54	2	0	0	59	2	0	1	0	0	3	117
02:15 PM	5	41	0	0	1	47	0	2	3	0	1	6	1	47	3	0	0	51	1	0	0	0	0	1	105
02:30 PM	6	40	0	0	2	48	0	1	1	0	0	2	1	52	4	0	0	57	2	1	1	0	1	5	112
02:45 PM	8	49	1	0	0	58	1	2	3	0	0	6	3	60	4	0	0	67	1	0	1	0	0	2	133
Total	28	169	3	0	3	203	1	9	8	0	1	19	8	213	13	0	0	234	6	1	3	0	1	11	467
03:00 PM	9	65	4	0	1	79	1	1	3	0	3	8	1	56	3	0	1	61	3	2	3	0	0	8	156
03:15 PM	11	52	4	0	0	67	3	1	1	0	1	6	2	70	3	0	0	75	0	0	2	0	0	2	150
03:30 PM	8	61	7	0	2	78	1	0	2	0	1	4	3	110	3	0	0	116	3	0	3	0	3	9	207
03:45 PM	9	53	2	0	1	65	0	2	1	0	0	3	2	92	7	0	0	101	6	0	5	0	0	11	180
Total	37	231	17	0	4	289	5	4	7	0	5	21	8	328	16	0	1	353	12	2	13	0	3	30	693
04:00 PM	3	63	2	0	1	69	2	1	2	0	1	6	2	99	6	0	1	108	5	1	5	0	1	12	195
04:15 PM	8	55	2	0	0	65	1	3	4	0	1	9	2	95	3	0	0	100	3	0	4	0	0	7	181
04:30 PM	9	67	1	0	0	77	1	1	3	0	0	5	4	104	2	0	0	110	3	1	7	0	0	11	203
04:45 PM	7	77	3	0	1	88	1	2	1	0	0	4	6	88	7	0	1	102	1	1	2	0	1	5	199
Total	27	262	8	0	2	299	5	7	10	0	2	24	14	386	18	0	2	420	12	3	18	0	2	35	778
05:00 PM	13	63	2	0	0	78	2	4	5	0	1	12	6	124	6	0	0	136	2	0	5	0	0	7	233
05:15 PM	7	73	5	0	1	86	1	0	5	0	2	8	7	113	2	0	0	122	3	1	2	0	0	6	222
05:30 PM	16	74	3	0	1	94	2	1	1	0	0	4	3	95	5	0	0	103	2	1	7	0	2	12	213
05:45 PM	7	78	2	0	3	90	0	2	5	0	2	9	1	96	5	0	0	102	4	0	2	0	0	6	207
Total	43	288	12	0	5	348	5	7	16	0	5	33	17	428	18	0	0	463	11	2	16	0	2	31	875
06:00 PM	10	57	3	0	0	70	1	1	5	0	1	8	5	88	5	0	0	98	2	2	4	0	0	8	184
06:15 PM	6	54	2	0	1	63	2	1	2	0	2	7	2	59	5	0	0	66	3	1	3	0	0	7	143
06:30 PM	3	45	2	0	0	50	0	3	3	0	0	6	2	66	1	0	0	69	5	0	4	0	0	9	134
06:45 PM	6	57	3	0	1	67	1	0	0	0	0	1	7	64	3	0	1	75	4	1	5	0	0	10	153
Total	25	213	10	0	2	250	4	5	10	0	3	22	16	277	14	0	1	308	14	4	16	0	0	34	614
Grand Total	331	3148	82	1	32	3594	44	75	110	0	34	263	108	2671	167	1	8	2955	98	19	126	0	10	253	7065
Apprch %	9.2	87.6	2.3	0	0.9		16.7	28.5	41.8	0	12.9		3.7	90.4	5.7	0	0.3		38.7	7.5	49.8	0	4		
Total %	4.7	44.6	1.2	0	0.5	50.9	0.6	1.1	1.6	0	0.5	3.7	1.5	37.8	2.4	0	0.1	41.8	1.4	0.3	1.8	0	0.1	3.6	
Cars +	311	3093	76	1	31	3512	41	71	106	0	33	251	105	2643	107	1	8	2864	96	18	119	0	10	243	6870
% Cars +	94	98.3	92.7	100	96.9	97.7	93.2	94.7	96.4	0	97.1	95.4	97.2	99	64.1	100	100	96.9	98	94.7	94.4	0	100	96	97.2
Trucks	20	55	6	0	1	82	3	4	4	0	1	12	3	28	60	0	0	91	2	1	7	0	0	10	195
% Trucks	6	1.7	7.3	0	3.1	2.3	6.8	5.3	3.6	0	2.9	4.6	2.8	1	35.9	0	0	3.1	2	5.3	5.6	0	0	4	2.8



TRAFFIC DATA COLLECTION

File Name : Blacksburg(Main and Givens) Day 1
 Site Code :
 Start Date : 4/12/2022
 Page No : 3

Start Time	N Main Street Southbound						Mountain Breeze Drive Westbound						N Main Street Northbound						Givens Lane Eastbound						Int. Total
	Right	Thru	Left	UTrn	Peds	App. Total	Right	Thru	Left	UTrn	Peds	App. Total	Right	Thru	Left	UTrn	Peds	App. Total	Right	Thru	Left	UTrn	Peds	App. Total	
Peak Hour Analysis From 07:00 AM to 11:45 AM - Peak 1 of 1																									
Peak Hour for Entire Intersection Begins at 08:30 AM																									
08:30 AM	12	132	3	0	2	149	1	3	2	0	0	6	0	23	3	0	0	26	3	0	2	0	0	5	186
08:45 AM	12	119	0	0	2	133	4	3	3	0	0	10	1	46	4	0	0	51	3	1	3	0	0	7	201
09:00 AM	5	92	4	0	3	104	0	1	3	0	0	4	1	46	4	0	0	51	1	0	4	0	0	5	164
09:15 AM	8	79	2	0	0	89	1	2	3	0	0	6	4	35	1	0	0	40	1	0	1	0	0	2	137
Total Volume	37	422	9	0	7	475	6	9	11	0	0	26	6	150	12	0	0	168	8	1	10	0	0	19	688
% App. Total	7.8	88.8	1.9	0	1.5		23.1	34.6	42.3	0	0		3.6	89.3	7.1	0	0		42.1	5.3	52.6	0	0		
PHF	.771	.799	.563	.000	.583	.797	.375	.750	.917	.000	.000	.650	.375	.815	.750	.000	.000	.824	.667	.250	.625	.000	.000	.679	.856

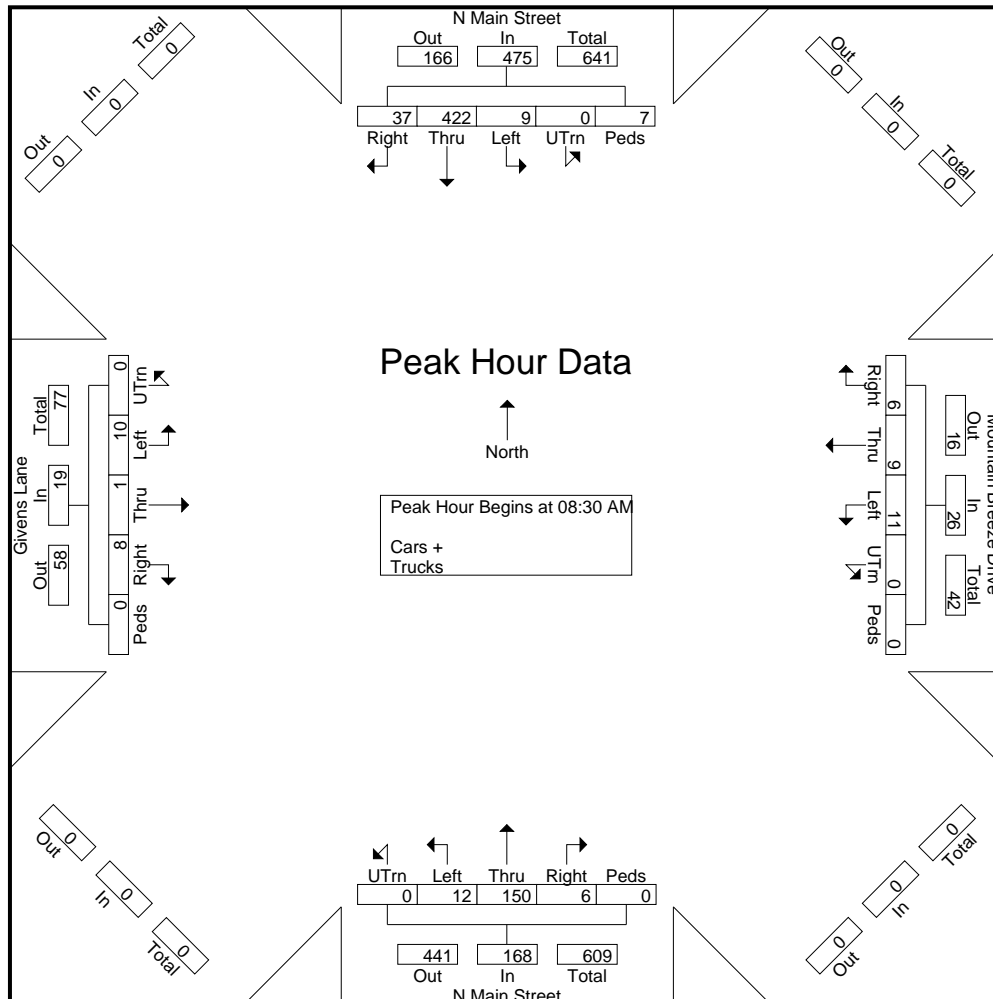



TRAFFIC DATA COLLECTION

File Name : Blacksburg(Main and Givens) Day 1
 Site Code :
 Start Date : 4/12/2022
 Page No : 4

Start Time	N Main Street Southbound						Mountain Breeze Drive Westbound						N Main Street Northbound						Givens Lane Eastbound						Int. Total
	Right	Thru	Left	UTrn	Peds	App. Total	Right	Thru	Left	UTrn	Peds	App. Total	Right	Thru	Left	UTrn	Peds	App. Total	Right	Thru	Left	UTrn	Peds	App. Total	
Peak Hour Analysis From 12:00 PM to 06:45 PM - Peak 1 of 1																									
Peak Hour for Entire Intersection Begins at 05:00 PM																									
05:00 PM	13	63	2	0	0	78	2	4	5	0	1	12	6	124	6	0	0	136	2	0	5	0	0	7	233
05:15 PM	7	73	5	0	1	86	1	0	5	0	2	8	7	113	2	0	0	122	3	1	2	0	0	6	222
05:30 PM	16	74	3	0	1	94	2	1	1	0	0	4	3	95	5	0	0	103	2	1	7	0	2	12	213
05:45 PM	7	78	2	0	3	90	0	2	5	0	2	9	1	96	5	0	0	102	4	0	2	0	0	6	207
Total Volume	43	288	12	0	5	348	5	7	16	0	5	33	17	428	18	0	0	463	11	2	16	0	2	31	875
% App. Total	12.4	82.8	3.4	0	1.4		15.2	21.2	48.5	0	15.2		3.7	92.4	3.9	0	0		35.5	6.5	51.6	0	6.5		
PHF	.672	.923	.600	.000	.417	.926	.625	.438	.800	.000	.625	.688	.607	.863	.750	.000	.000	.851	.688	.500	.571	.000	.250	.646	.939

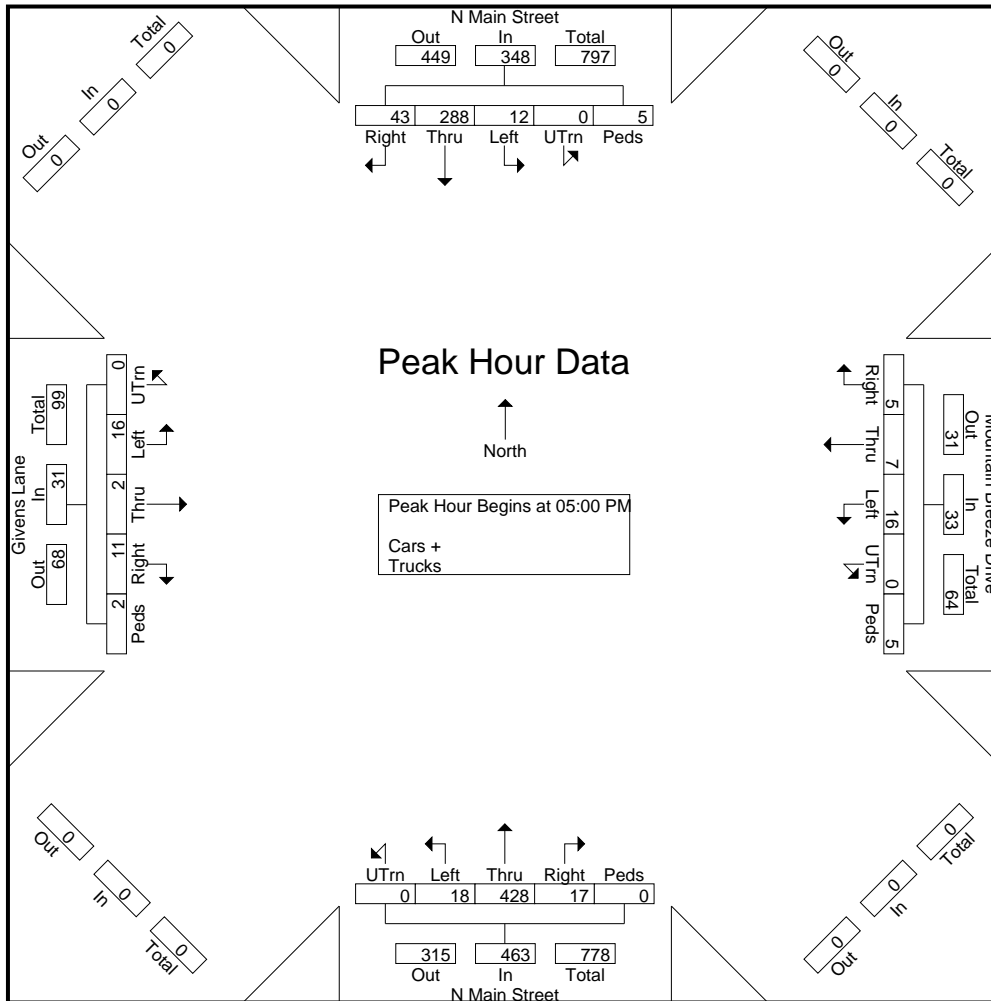



TRAFFIC DATA COLLECTION

File Name : Blacksburg(Main and Givens) Day 2

Site Code :

Start Date : 4/13/2022

Page No : 2

Groups Printed- Trucks

Start Time	N Main Street Southbound		Mountain Breeze Drive Westbound		N Main Street Northbound		Givens Lane Eastbound		Int. Total
	Bikes	App. Total	Bikes	App. Total	Bikes	App. Total	Bikes	App. Total	
02:45 PM	0	0	0	0	0	0	0	0	0
Total	0	0	0	0	0	0	0	0	0
03:00 PM	0	0	0	0	0	0	0	0	0
03:15 PM	0	0	0	0	1	1	0	0	1
03:30 PM	0	0	0	0	0	0	0	0	0
03:45 PM	0	0	0	0	0	0	0	0	0
Total	0	0	0	0	1	1	0	0	1
04:00 PM	0	0	0	0	0	0	0	0	0
04:15 PM	0	0	0	0	0	0	0	0	0
04:30 PM	0	0	0	0	0	0	0	0	0
04:45 PM	0	0	0	0	0	0	0	0	0
Total	0	0	0	0	0	0	0	0	0
05:00 PM	0	0	0	0	0	0	0	0	0
05:15 PM	0	0	0	0	0	0	0	0	0
05:30 PM	0	0	0	0	0	0	0	0	0
05:45 PM	0	0	0	0	0	0	0	0	0
Total	0	0	0	0	0	0	0	0	0
06:00 PM	0	0	0	0	0	0	0	0	0
06:15 PM	0	0	0	0	0	0	0	0	0
06:30 PM	0	0	0	0	0	0	0	0	0
06:45 PM	0	0	0	0	0	0	0	0	0
Total	0	0	0	0	0	0	0	0	0
Grand Total	2	2	0	0	1	1	0	0	3
Apprch %	100		0		100		0		
Total %	66.7	66.7	0	0	33.3	33.3	0	0	



TRAFFIC DATA COLLECTION

File Name : Blacksburg(Main and Givens) Day 2

Site Code :

Start Date : 4/13/2022

Page No : 3

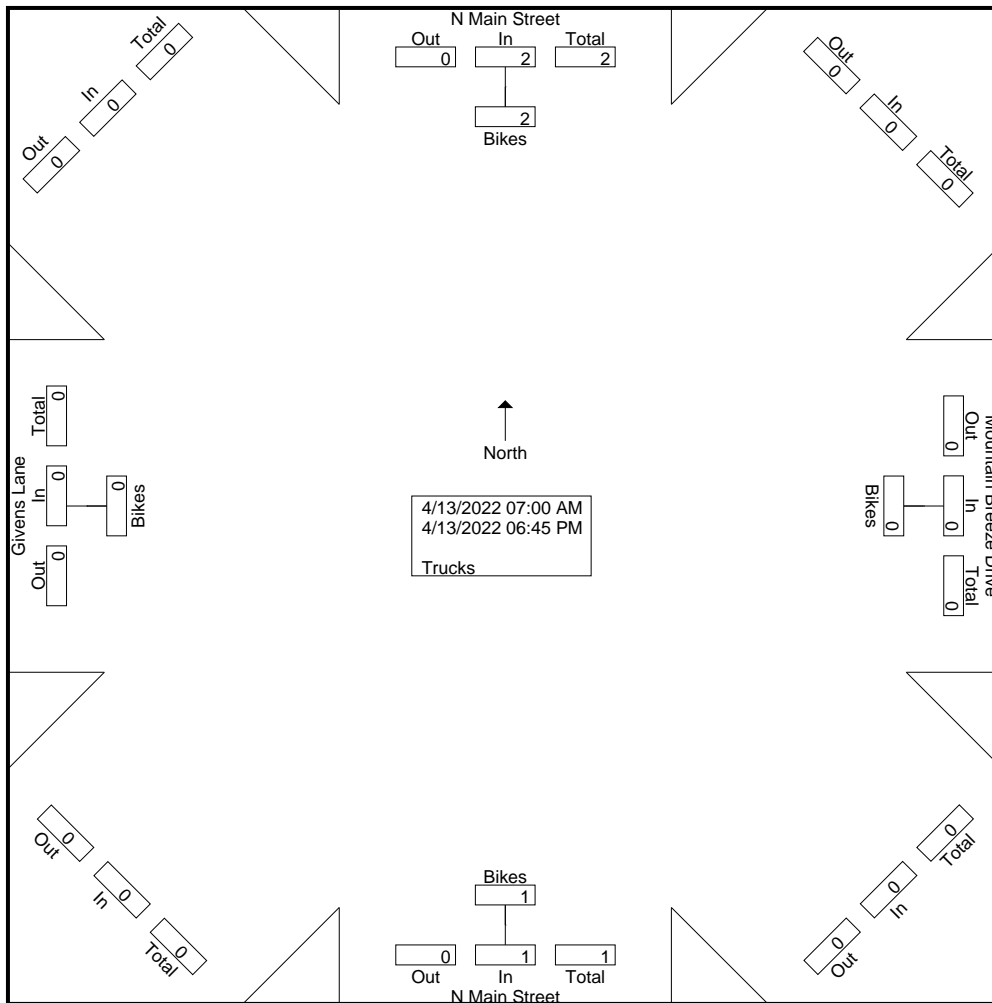



TRAFFIC DATA COLLECTION

File Name : Blacksburg(Main and Givens) Day 2
 Site Code :
 Start Date : 4/13/2022
 Page No : 1

Groups Printed- Cars +

Start Time	N Main Street Southbound		Mountain Breeze Drive Westbound		N Main Street Northbound		Givens Lane Eastbound		Int. Total
	Peds	App. Total	Peds	App. Total	Peds	App. Total	Peds	App. Total	
07:00 AM	0	0	1	1	1	1	0	0	2
07:15 AM	0	0	0	0	0	0	0	0	0
07:30 AM	0	0	0	0	0	0	1	1	1
07:45 AM	0	0	1	1	1	1	0	0	2
Total	0	0	2	2	2	2	1	1	5
08:00 AM	0	0	0	0	0	0	0	0	0
08:15 AM	0	0	2	2	0	0	1	1	3
08:30 AM	0	0	4	4	1	1	0	0	5
08:45 AM	0	0	2	2	1	1	0	0	3
Total	0	0	8	8	2	2	1	1	11
09:00 AM	4	4	3	3	1	1	1	1	9
09:15 AM	0	0	3	3	0	0	1	1	4
09:30 AM	0	0	2	2	1	1	1	1	4
09:45 AM	0	0	0	0	1	1	2	2	3
Total	4	4	8	8	3	3	5	5	20
10:00 AM	0	0	1	1	0	0	1	1	2
10:15 AM	1	1	5	5	3	3	2	2	11
10:30 AM	0	0	0	0	0	0	2	2	2
10:45 AM	1	1	0	0	0	0	0	0	1
Total	2	2	6	6	3	3	5	5	16
11:00 AM	0	0	0	0	0	0	0	0	0
11:15 AM	0	0	0	0	0	0	0	0	0
11:30 AM	0	0	1	1	0	0	0	0	1
11:45 AM	1	1	0	0	0	0	1	1	2
Total	1	1	1	1	0	0	1	1	3
12:00 PM	0	0	2	2	1	1	0	0	3
12:15 PM	1	1	0	0	0	0	0	0	1
12:30 PM	0	0	0	0	0	0	0	0	0
12:45 PM	2	2	0	0	0	0	1	1	3
Total	3	3	2	2	1	1	1	1	7
01:00 PM	0	0	0	0	0	0	0	0	0
01:15 PM	0	0	0	0	0	0	0	0	0
01:30 PM	0	0	0	0	0	0	0	0	0
01:45 PM	1	1	0	0	0	0	0	0	1
Total	1	1	0	0	0	0	0	0	1
02:00 PM	0	0	0	0	0	0	0	0	0
02:15 PM	0	0	0	0	0	0	0	0	0
02:30 PM	0	0	2	2	2	2	0	0	4



TRAFFIC DATA COLLECTION

File Name : Blacksburg(Main and Givens) Day 2

Site Code :

Start Date : 4/13/2022

Page No : 2

Groups Printed- Cars +

Start Time	N Main Street Southbound		Mountain Breeze Drive Westbound		N Main Street Northbound		Givens Lane Eastbound		Int. Total
	Peds	App. Total	Peds	App. Total	Peds	App. Total	Peds	App. Total	
02:45 PM	0	0	0	0	0	0	0	0	0
Total	0	0	2	2	2	2	0	0	4
03:00 PM	0	0	0	0	0	0	0	0	0
03:15 PM	0	0	4	4	4	4	0	0	8
03:30 PM	0	0	0	0	0	0	0	0	0
03:45 PM	1	1	0	0	0	0	0	0	1
Total	1	1	4	4	4	4	0	0	9
04:00 PM	0	0	1	1	0	0	0	0	1
04:15 PM	0	0	0	0	0	0	0	0	0
04:30 PM	0	0	1	1	0	0	0	0	1
04:45 PM	3	3	1	1	0	0	0	0	4
Total	3	3	3	3	0	0	0	0	6
05:00 PM	1	1	0	0	0	0	0	0	1
05:15 PM	2	2	0	0	0	0	0	0	2
05:30 PM	2	2	0	0	0	0	0	0	2
05:45 PM	1	1	0	0	0	0	0	0	1
Total	6	6	0	0	0	0	0	0	6
06:00 PM	0	0	2	2	0	0	0	0	2
06:15 PM	3	3	1	1	0	0	0	0	4
06:30 PM	0	0	3	3	1	1	0	0	4
06:45 PM	0	0	1	1	0	0	1	1	2
Total	3	3	7	7	1	1	1	1	12
Grand Total	24	24	43	43	18	18	15	15	100
Apprch %	100		100		100		100		
Total %	24	24	43	43	18	18	15	15	



TRAFFIC DATA COLLECTION

File Name : Blacksburg(Main and Givens) Day 2

Site Code :

Start Date : 4/13/2022

Page No : 3

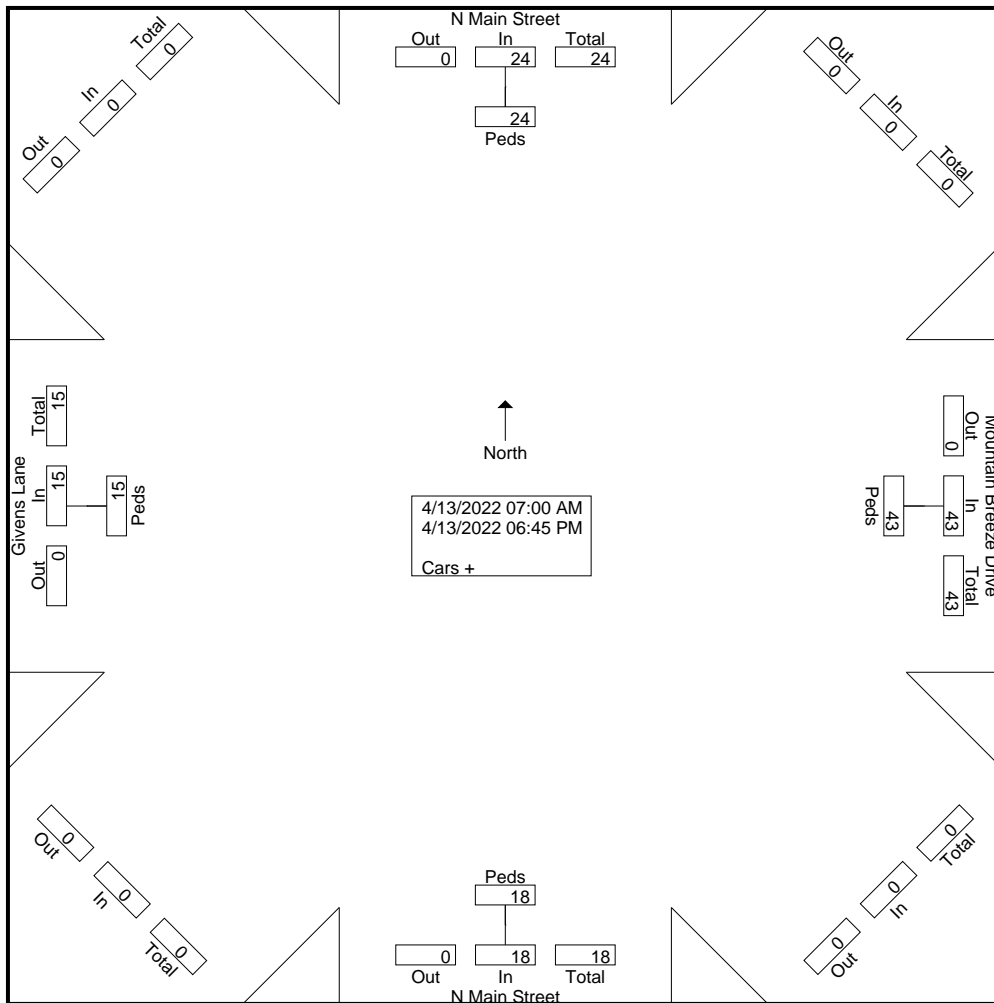



TRAFFIC DATA COLLECTION

File Name : Blacksburg(Main and Givens) Day 2
 Site Code :
 Start Date : 4/13/2022
 Page No : 1

Groups Printed- Cars + - Trucks

Start Time	N Main Street Southbound						Mountain Breeze Drive Westbound						N Main Street Northbound						Givens Lane Eastbound						Int. Total
	Right	Thru	Left	UTrn	Peds	App. Total	Right	Thru	Left	UTrn	Peds	App. Total	Right	Thru	Left	UTrn	Peds	App. Total	Right	Thru	Left	UTrn	Peds	App. Total	
07:00 AM	5	60	1	0	0	66	1	1	2	0	1	5	3	16	4	0	1	24	0	0	1	0	0	1	96
07:15 AM	6	97	0	0	0	103	2	4	1	0	0	7	1	13	3	0	0	17	3	0	1	0	0	4	131
07:30 AM	10	119	2	0	0	131	0	6	6	0	0	12	0	19	3	0	0	22	3	1	3	0	1	8	173
07:45 AM	14	123	1	0	0	138	2	3	5	0	1	11	0	27	4	0	1	32	2	0	0	0	0	2	183
Total	35	399	4	0	0	438	5	14	14	0	2	35	4	75	14	0	2	95	8	1	5	0	1	15	583
08:00 AM	9	87	2	0	0	98	0	2	2	0	0	4	1	36	2	0	0	39	1	0	5	0	0	6	147
08:15 AM	9	83	0	0	0	92	0	1	4	0	2	7	3	26	2	0	0	31	1	1	1	0	1	4	134
08:30 AM	9	128	0	0	0	137	2	3	1	0	4	10	2	46	2	0	1	51	3	0	4	0	0	7	205
08:45 AM	15	122	2	0	0	139	2	3	4	0	2	11	1	52	3	0	1	57	4	0	6	0	0	10	217
Total	42	420	4	0	0	466	4	9	11	0	8	32	7	160	9	0	2	178	9	1	16	0	1	27	703
09:00 AM	12	88	3	0	5	108	0	1	5	0	3	9	2	47	4	0	1	54	1	0	1	0	1	3	174
09:15 AM	5	76	2	0	0	83	3	1	3	0	3	10	0	39	3	0	0	42	0	0	4	0	1	5	140
09:30 AM	7	55	0	0	0	62	0	1	2	0	2	5	0	54	6	0	1	61	2	0	1	0	1	4	132
09:45 AM	3	52	0	0	0	55	0	1	2	0	0	3	2	30	4	0	1	37	0	0	2	0	2	4	99
Total	27	271	5	0	5	308	3	4	12	0	8	27	4	170	17	0	3	194	3	0	8	0	5	16	545
10:00 AM	3	60	0	0	0	63	0	2	1	0	1	4	2	26	1	1	0	30	4	2	1	0	1	8	105
10:15 AM	4	45	4	0	1	54	1	1	2	0	5	9	1	41	2	0	3	47	3	0	0	0	2	5	115
10:30 AM	8	57	0	0	0	65	1	0	2	0	0	3	0	45	2	0	0	47	2	0	0	0	2	4	119
10:45 AM	9	60	0	0	1	70	0	3	2	0	0	5	2	32	4	0	0	38	1	1	5	0	0	7	120
Total	24	222	4	0	2	252	2	6	7	0	6	21	5	144	9	1	3	162	10	3	6	0	5	24	459
11:00 AM	8	79	3	0	0	90	0	0	1	0	0	1	5	42	3	0	0	50	3	0	5	0	0	8	149
11:15 AM	11	57	0	0	0	68	0	0	3	0	0	3	2	43	2	0	0	47	4	0	4	0	0	8	126
11:30 AM	4	61	0	0	0	65	0	0	5	0	1	6	1	45	4	0	0	50	5	1	4	0	0	10	131
11:45 AM	4	74	2	0	2	82	2	2	4	0	0	8	1	65	6	0	0	72	5	0	1	0	1	7	169
Total	27	271	5	0	2	305	2	2	13	0	1	18	9	195	15	0	0	219	17	1	14	0	1	33	575
12:00 PM	8	73	0	0	0	81	0	0	4	0	2	6	3	71	2	0	1	77	6	0	2	0	0	8	172
12:15 PM	5	58	1	0	1	65	0	0	3	0	0	3	2	46	2	0	0	50	0	2	1	0	0	3	121
12:30 PM	8	57	2	0	0	67	0	0	0	0	0	0	0	63	4	0	0	67	0	0	1	0	0	1	135
12:45 PM	5	59	2	0	2	68	1	0	3	0	0	4	0	49	5	0	0	54	4	1	1	0	1	7	133
Total	26	247	5	0	3	281	1	0	10	0	2	13	5	229	13	0	1	248	10	3	5	0	1	19	561
01:00 PM	4	56	1	0	0	61	0	1	3	0	0	4	5	63	4	0	0	72	2	1	2	0	0	5	142
01:15 PM	5	53	1	0	0	59	1	1	2	0	0	4	3	50	1	0	0	54	1	0	1	0	0	2	119
01:30 PM	6	53	0	0	0	59	0	0	3	0	0	3	6	45	1	0	0	52	2	0	2	0	0	4	118
01:45 PM	3	50	1	0	1	55	1	1	6	0	0	8	2	48	3	0	0	53	5	1	2	0	0	8	124
Total	18	212	3	0	1	234	2	3	14	0	0	19	16	206	9	0	0	231	10	2	7	0	0	19	503



TRAFFIC DATA COLLECTION

File Name : Blacksburg(Main and Givens) Day 2

Site Code :

Start Date : 4/13/2022

Page No : 2

Groups Printed- Cars + - Trucks

Start Time	N Main Street Southbound						Mountain Breeze Drive Westbound						N Main Street Northbound						Givens Lane Eastbound						Int. Total
	Right	Thru	Left	UTrn	Peds	App. Total	Right	Thru	Left	UTrn	Peds	App. Total	Right	Thru	Left	UTrn	Peds	App. Total	Right	Thru	Left	UTrn	Peds	App. Total	
02:00 PM	3	46	1	0	0	50	1	0	5	0	0	6	3	56	4	0	0	63	5	1	0	0	0	6	125
02:15 PM	8	62	1	0	0	71	0	1	3	0	0	4	0	56	2	0	0	58	1	0	3	0	0	4	137
02:30 PM	9	42	1	0	0	52	1	3	4	0	2	10	4	49	3	0	2	58	0	0	2	0	0	2	122
02:45 PM	6	33	1	0	0	40	2	1	0	0	0	3	1	76	5	0	0	82	2	2	0	0	0	4	129
Total	26	183	4	0	0	213	4	5	12	0	2	23	8	237	14	0	2	261	8	3	5	0	0	16	513
03:00 PM	6	59	2	0	0	67	1	1	1	0	0	3	2	74	1	0	0	77	1	0	1	0	0	2	149
03:15 PM	10	75	2	0	0	87	1	0	3	0	4	8	3	73	2	0	5	83	1	0	7	0	0	8	186
03:30 PM	8	88	2	0	0	98	1	0	4	0	0	5	1	126	6	0	0	133	4	2	2	0	0	8	244
03:45 PM	5	56	3	0	1	65	3	2	2	0	0	7	2	105	3	0	0	110	1	1	1	0	0	3	185
Total	29	278	9	0	1	317	6	3	10	0	4	23	8	378	12	0	5	403	7	3	11	0	0	21	764
04:00 PM	12	67	1	0	0	80	2	5	2	0	1	10	4	110	6	0	0	120	3	0	3	0	0	6	216
04:15 PM	3	55	2	0	0	60	0	4	2	0	0	6	5	96	8	0	0	109	6	0	6	0	0	12	187
04:30 PM	9	66	4	0	0	79	0	3	1	0	1	5	1	122	10	0	0	133	0	1	8	0	0	9	226
04:45 PM	11	67	0	0	3	81	2	5	3	0	1	11	2	75	5	0	0	82	3	1	3	0	0	7	181
Total	35	255	7	0	3	300	4	17	8	0	3	32	12	403	29	0	0	444	12	2	20	0	0	34	810
05:00 PM	11	77	2	0	1	91	0	2	4	0	0	6	2	112	7	0	0	121	2	2	4	0	0	8	226
05:15 PM	7	56	2	0	2	67	3	1	2	0	0	6	4	125	4	0	0	133	4	2	3	0	0	9	215
05:30 PM	13	73	5	0	2	93	3	1	8	0	0	12	8	104	5	0	0	117	7	0	4	0	0	11	233
05:45 PM	8	83	3	0	1	95	1	2	6	0	0	9	8	101	7	0	0	116	3	0	5	0	0	8	228
Total	39	289	12	0	6	346	7	6	20	0	0	33	22	442	23	0	0	487	16	4	16	0	0	36	902
06:00 PM	13	56	2	0	0	71	1	3	1	0	2	7	5	81	4	0	0	90	3	1	2	0	0	6	174
06:15 PM	4	66	3	0	3	76	1	1	4	0	1	7	2	66	2	0	0	70	5	0	3	0	0	8	161
06:30 PM	7	38	2	0	0	47	1	1	1	0	3	6	2	59	1	0	1	63	1	0	2	0	0	3	119
06:45 PM	7	48	2	0	0	57	0	1	1	0	1	3	5	60	3	0	0	68	1	0	1	0	1	3	131
Total	31	208	9	0	3	251	3	6	7	0	7	23	14	266	10	0	1	291	10	1	8	0	1	20	585
Grand Total	359	3255	71	0	26	3711	43	75	138	0	43	299	114	2905	174	1	19	3213	120	24	121	0	15	280	7503
Apprch %	9.7	87.7	1.9	0	0.7		14.4	25.1	46.2	0	14.4		3.5	90.4	5.4	0	0.6		42.9	8.6	43.2	0	5.4		
Total %	4.8	43.4	0.9	0	0.3	49.5	0.6	1	1.8	0	0.6	4	1.5	38.7	2.3	0	0.3	42.8	1.6	0.3	1.6	0	0.2	3.7	
Cars +	343	3196	70	0	24	3633	40	74	137	0	43	294	114	2848	114	1	18	3095	113	21	119	0	15	268	7290
% Cars +	95.5	98.2	98.6	0	92.3	97.9	93	98.7	99.3	0	100	98.3	100	98	65.5	100	94.7	96.3	94.2	87.5	98.3	0	100	95.7	97.2
Trucks	16	59	1	0	2	78	3	1	1	0	0	5	0	57	60	0	1	118	7	3	2	0	0	12	213
% Trucks	4.5	1.8	1.4	0	7.7	2.1	7	1.3	0.7	0	0	1.7	0	2	34.5	0	5.3	3.7	5.8	12.5	1.7	0	0	4.3	2.8



TRAFFIC DATA COLLECTION

File Name : Blacksburg(Main and Givens) Day 2
 Site Code :
 Start Date : 4/13/2022
 Page No : 3

Start Time	N Main Street Southbound						Mountain Breeze Drive Westbound						N Main Street Northbound						Givens Lane Eastbound						Int. Total
	Right	Thru	Left	UTrn	Peds	App. Total	Right	Thru	Left	UTrn	Peds	App. Total	Right	Thru	Left	UTrn	Peds	App. Total	Right	Thru	Left	UTrn	Peds	App. Total	
Peak Hour Analysis From 07:00 AM to 11:45 AM - Peak 1 of 1																									
Peak Hour for Entire Intersection Begins at 08:30 AM																									
08:30 AM	9	128	0	0	0	137	2	3	1	0	4	10	2	46	2	0	1	51	3	0	4	0	0	7	205
08:45 AM	15	122	2	0	0	139	2	3	4	0	2	11	1	52	3	0	1	57	4	0	6	0	0	10	217
09:00 AM	12	88	3	0	5	108	0	1	5	0	3	9	2	47	4	0	1	54	1	0	1	0	1	3	174
09:15 AM	5	76	2	0	0	83	3	1	3	0	3	10	0	39	3	0	0	42	0	0	4	0	1	5	140
Total Volume	41	414	7	0	5	467	7	8	13	0	12	40	5	184	12	0	3	204	8	0	15	0	2	25	736
% App. Total	8.8	88.7	1.5	0	1.1		17.5	20	32.5	0	30		2.5	90.2	5.9	0	1.5		32	0	60	0	8		
PHF	.683	.809	.583	.000	.250	.840	.583	.667	.650	.000	.750	.909	.625	.885	.750	.000	.750	.895	.500	.000	.625	.000	.500	.625	.848

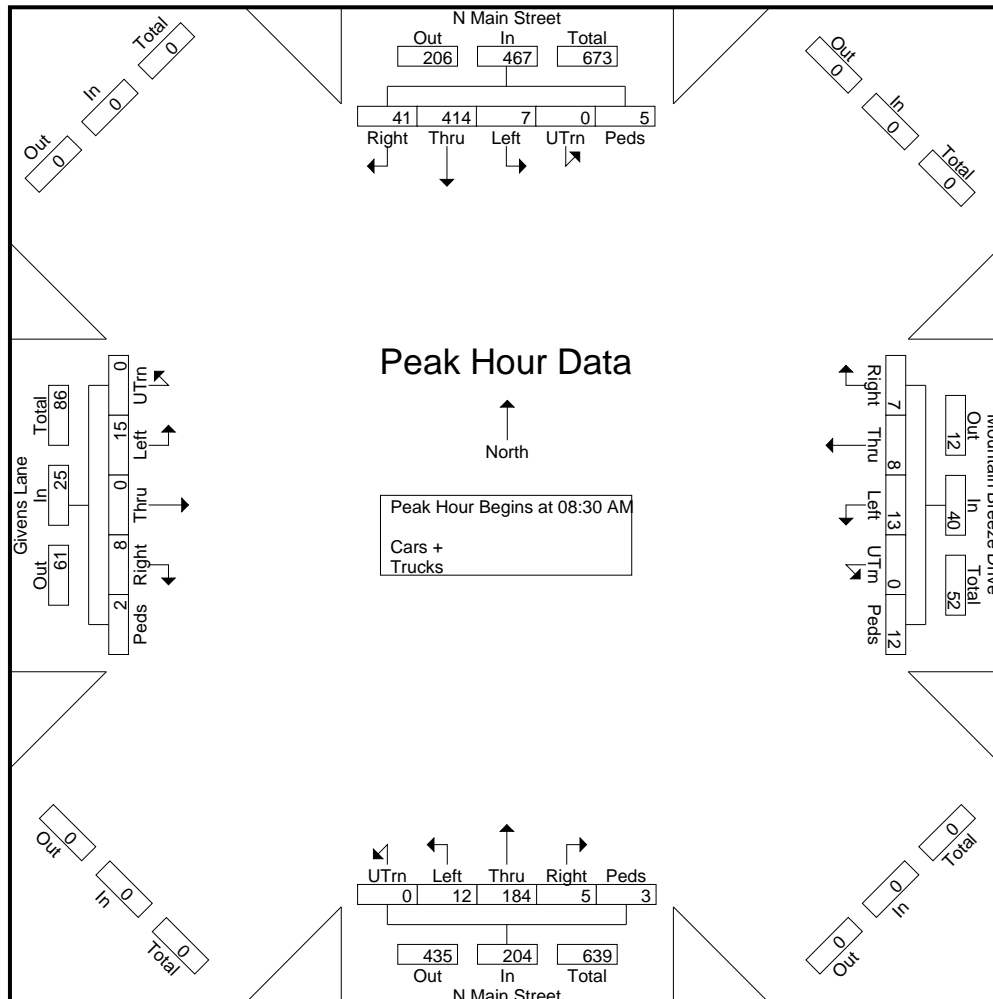



TRAFFIC DATA COLLECTION

File Name : Blacksburg(Main and Givens) Day 2
 Site Code :
 Start Date : 4/13/2022
 Page No : 4

Start Time	N Main Street Southbound					Mountain Breeze Drive Westbound					N Main Street Northbound					Givens Lane Eastbound					Int. Total				
	Right	Thru	Left	UTrn	Peds	App. Total	Right	Thru	Left	UTrn	Peds	App. Total	Right	Thru	Left	UTrn	Peds	App. Total	Right	Thru		Left	UTrn	Peds	App. Total
Peak Hour Analysis From 12:00 PM to 06:45 PM - Peak 1 of 1																									
Peak Hour for Entire Intersection Begins at 05:00 PM																									
05:00 PM	11	77	2	0	1	91	0	2	4	0	0	6	2	112	7	0	0	121	2	2	4	0	0	8	226
05:15 PM	7	56	2	0	2	67	3	1	2	0	0	6	4	125	4	0	0	133	4	2	3	0	0	9	215
05:30 PM	13	73	5	0	2	93	3	1	8	0	0	12	8	104	5	0	0	117	7	0	4	0	0	11	233
05:45 PM	8	83	3	0	1	95	1	2	6	0	0	9	8	101	7	0	0	116	3	0	5	0	0	8	228
Total Volume	39	289	12	0	6	346	7	6	20	0	0	33	22	442	23	0	0	487	16	4	16	0	0	36	902
% App. Total	11.3	83.5	3.5	0	1.7		21.2	18.2	60.6	0	0		4.5	90.8	4.7	0	0		44.4	11.1	44.4	0	0		
PHF	.750	.870	.600	.000	.750	.911	.583	.750	.625	.000	.000	.688	.688	.884	.821	.000	.000	.915	.571	.500	.800	.000	.000	.818	.968

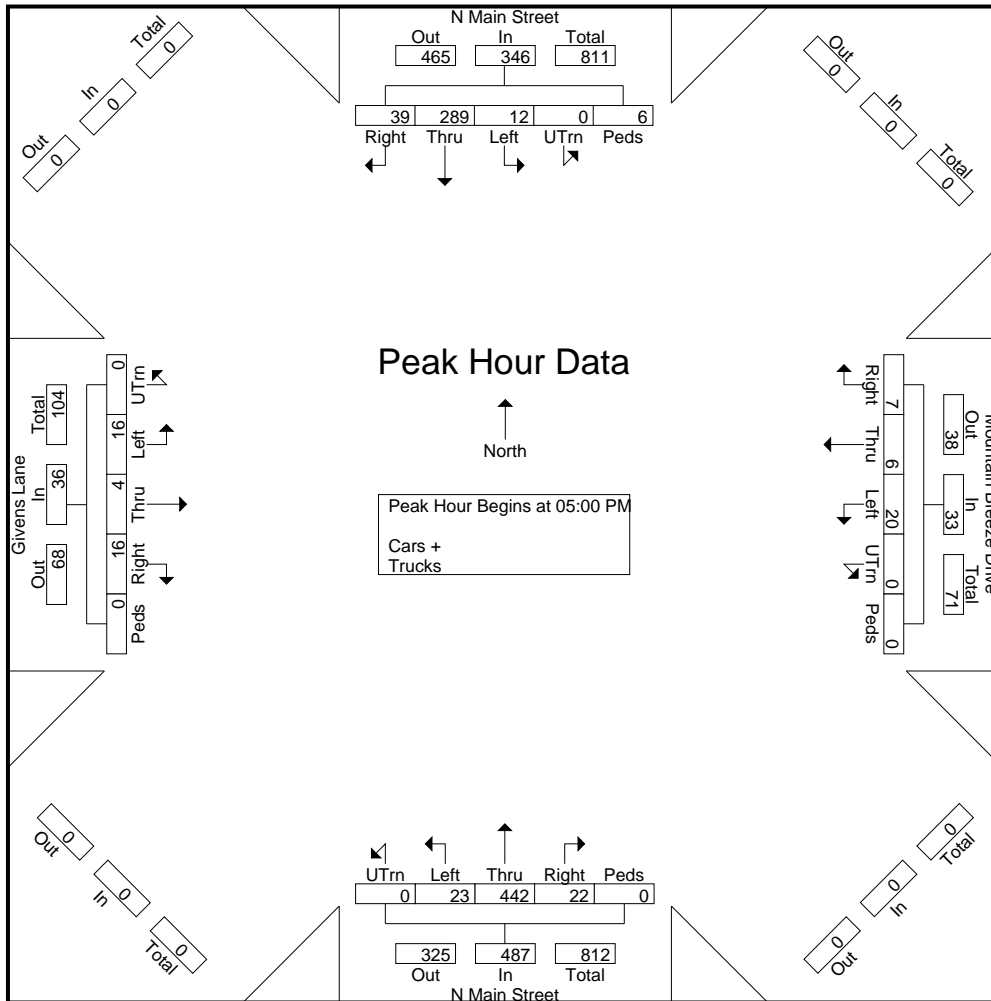



TRAFFIC DATA COLLECTION

File Name : Blacksburg(N Main Street and Countryside Court) 10-18
 Site Code :
 Start Date : 10/18/2022
 Page No : 1

Groups Printed- Cars + - Trucks

Start Time	N Main Street Southbound					N Main Street Northbound					Countryside Court Eastbound					Int. Total
	Right	Thru	UTrn	Peds	App. Total	Thru	Left	UTrn	Peds	App. Total	Right	Left	UTrn	Peds	App. Total	
07:00 AM	0	61	0	0	61	20	0	0	0	20	0	0	0	0	0	81
07:15 AM	1	105	0	0	106	14	4	0	0	18	4	1	0	0	5	129
07:30 AM	2	138	0	0	140	21	0	0	0	21	5	0	0	1	6	167
07:45 AM	1	122	0	0	123	19	1	0	0	20	5	4	0	0	9	152
Total	4	426	0	0	430	74	5	0	0	79	14	5	0	1	20	529
08:00 AM	2	80	0	1	83	35	0	0	0	35	2	0	0	0	2	120
08:15 AM	2	104	0	0	106	22	1	0	0	23	4	2	0	0	6	135
08:30 AM	1	129	0	0	130	32	2	0	0	34	6	2	0	0	8	172
08:45 AM	2	140	0	0	142	50	3	0	0	53	4	2	0	0	6	201
Total	7	453	0	1	461	139	6	0	0	145	16	6	0	0	22	628
09:00 AM	2	114	0	2	118	50	2	0	0	52	4	2	0	1	7	177
09:15 AM	0	78	0	0	78	38	4	0	0	42	3	1	0	0	4	124
09:30 AM	1	57	0	0	58	35	4	0	0	39	2	1	0	0	3	100
09:45 AM	1	45	0	0	46	26	3	0	0	29	2	0	0	0	2	77
Total	4	294	0	2	300	149	13	0	0	162	11	4	0	1	16	478
10:00 AM	2	50	0	0	52	29	2	0	1	32	2	1	0	0	3	87
10:15 AM	1	56	0	0	57	32	0	0	0	32	3	1	0	0	4	93
10:30 AM	1	70	0	0	71	28	2	0	0	30	5	0	0	0	5	106
10:45 AM	1	42	0	2	45	41	3	0	0	44	7	1	0	0	8	97
Total	5	218	0	2	225	130	7	0	1	138	17	3	0	0	20	383
11:00 AM	1	75	0	0	76	31	1	0	0	32	2	1	0	0	3	111
11:15 AM	2	74	0	0	76	40	1	0	0	41	3	1	0	0	4	121
11:30 AM	1	55	0	2	58	38	4	0	0	42	3	0	0	0	3	103
11:45 AM	1	71	0	0	72	63	5	0	0	68	1	2	0	0	3	143
Total	5	275	0	2	282	172	11	0	0	183	9	4	0	0	13	478
12:00 PM	1	65	0	2	68	49	1	0	0	50	2	1	0	0	3	121
12:15 PM	0	59	1	0	60	50	2	0	0	52	2	0	0	0	2	114
12:30 PM	2	64	0	0	66	64	3	0	0	67	2	0	0	0	2	135
12:45 PM	3	57	0	0	60	56	4	1	0	61	3	3	0	0	6	127
Total	6	245	1	2	254	219	10	1	0	230	9	4	0	0	13	497
01:00 PM	2	58	0	0	60	50	2	0	0	52	5	0	0	0	5	117
01:15 PM	1	51	0	0	52	47	2	0	0	49	1	0	0	1	2	103
01:30 PM	3	61	0	2	66	43	2	0	0	45	2	0	0	0	2	113
01:45 PM	2	45	0	0	47	47	0	0	0	47	3	2	0	0	5	99
Total	8	215	0	2	225	187	6	0	0	193	11	2	0	1	14	432
02:00 PM	1	40	0	1	42	50	1	0	0	51	4	1	0	0	5	98
02:15 PM	2	47	0	0	49	51	3	0	0	54	3	0	0	0	3	106
02:30 PM	1	65	0	0	66	38	1	0	0	39	3	1	0	0	4	109



TRAFFIC DATA COLLECTION

File Name : Blacksburg(N Main Street and Countryside Court) 10-18

Site Code :

Start Date : 10/18/2022

Page No : 2

Groups Printed- Cars + - Trucks

Start Time	N Main Street Southbound					N Main Street Northbound					Countryside Court Eastbound					Int. Total
	Right	Thru	UTrn	Peds	App. Total	Thru	Left	UTrn	Peds	App. Total	Right	Left	UTrn	Peds	App. Total	
02:45 PM	7	49	0	0	56	67	2	0	0	69	2	0	0	0	2	127
Total	11	201	0	1	213	206	7	0	0	213	12	2	0	0	14	440
03:00 PM	5	59	0	1	65	52	1	0	0	53	4	1	0	0	5	123
03:15 PM	2	63	0	0	65	84	5	0	0	89	1	0	0	0	1	155
03:30 PM	1	65	0	2	68	93	1	0	0	94	2	2	0	0	4	166
03:45 PM	0	68	0	1	69	93	3	0	0	96	3	0	0	0	3	168
Total	8	255	0	4	267	322	10	0	0	332	10	3	0	0	13	612
04:00 PM	0	72	0	1	73	102	1	0	0	103	4	1	0	0	5	181
04:15 PM	1	80	0	0	81	81	0	0	0	81	3	0	0	0	3	165
04:30 PM	4	79	0	0	83	123	1	0	0	124	3	2	0	0	5	212
04:45 PM	4	97	0	0	101	118	3	0	0	121	5	1	0	0	6	228
Total	9	328	0	1	338	424	5	0	0	429	15	4	0	0	19	786
05:00 PM	3	73	0	0	76	148	8	0	0	156	6	0	0	0	6	238
05:15 PM	1	89	0	0	90	112	8	0	0	120	5	0	0	0	5	215
05:30 PM	1	66	0	0	67	116	6	0	0	122	1	1	0	0	2	191
05:45 PM	4	68	0	0	72	80	1	0	0	81	2	0	0	0	2	155
Total	9	296	0	0	305	456	23	0	0	479	14	1	0	0	15	799
06:00 PM	0	60	0	0	60	81	7	0	0	88	1	0	0	0	1	149
06:15 PM	1	57	0	0	58	69	2	0	0	71	0	0	0	0	0	129
06:30 PM	3	58	0	0	61	74	5	0	0	79	3	2	0	0	5	145
06:45 PM	0	52	0	0	52	61	2	0	0	63	2	3	0	0	5	120
Total	4	227	0	0	231	285	16	0	0	301	6	5	0	0	11	543
Grand Total	80	3433	1	17	3531	2763	119	1	1	2884	144	43	0	3	190	6605
Apprch %	2.3	97.2	0	0.5		95.8	4.1	0	0		75.8	22.6	0	1.6		
Total %	1.2	52	0	0.3	53.5	41.8	1.8	0	0	43.7	2.2	0.7	0	0	2.9	
Cars +	78	3392	1	17	3488	2746	114	1	1	2862	137	42	0	3	182	6532
% Cars +	97.5	98.8	100	100	98.8	99.4	95.8	100	100	99.2	95.1	97.7	0	100	95.8	98.9
Trucks	2	41	0	0	43	17	5	0	0	22	7	1	0	0	8	73
% Trucks	2.5	1.2	0	0	1.2	0.6	4.2	0	0	0.8	4.9	2.3	0	0	4.2	1.1



TRAFFIC DATA COLLECTION

File Name : Blacksburg(N Main Street and Countryside Court) 10-18
 Site Code :
 Start Date : 10/18/2022
 Page No : 3

Start Time	N Main Street Southbound					N Main Street Northbound					Countryside Court Eastbound					Int. Total
	Right	Thru	UTrn	Peds	App. Total	Thru	Left	UTrn	Peds	App. Total	Right	Left	UTrn	Peds	App. Total	
Peak Hour Analysis From 07:00 AM to 11:45 AM - Peak 1 of 1																
Peak Hour for Entire Intersection Begins at 08:15 AM																
08:15 AM	2	104	0	0	106	22	1	0	0	23	4	2	0	0	6	135
08:30 AM	1	129	0	0	130	32	2	0	0	34	6	2	0	0	8	172
08:45 AM	2	140	0	0	142	50	3	0	0	53	4	2	0	0	6	201
09:00 AM	2	114	0	2	118	50	2	0	0	52	4	2	0	1	7	177
Total Volume	7	487	0	2	496	154	8	0	0	162	18	8	0	1	27	685
% App. Total	1.4	98.2	0	0.4		95.1	4.9	0	0		66.7	29.6	0	3.7		
PHF	.875	.870	.000	.250	.873	.770	.667	.000	.000	.764	.750	1.00	.000	.250	.844	.852

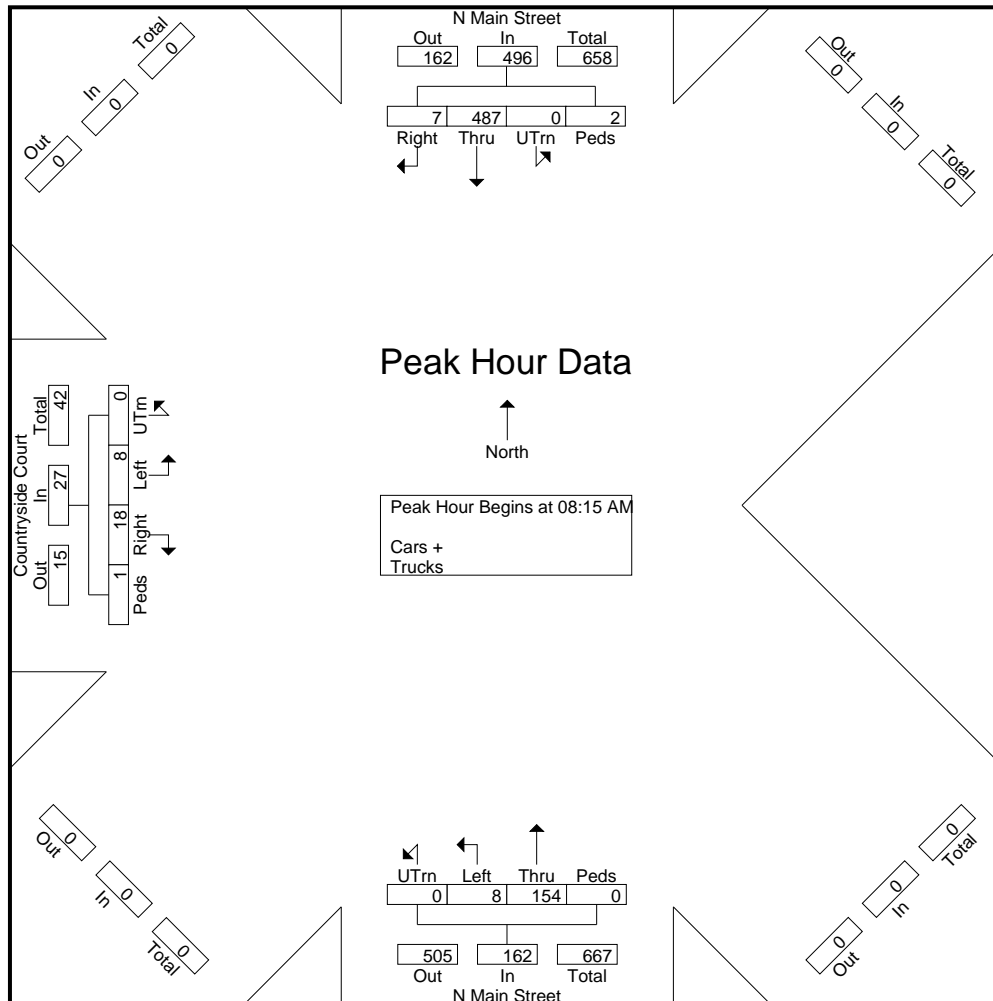



TRAFFIC DATA COLLECTION

File Name : Blacksburg(N Main Street and Countryside Court) 10-18
 Site Code :
 Start Date : 10/18/2022
 Page No : 4

Start Time	N Main Street Southbound					N Main Street Northbound					Countryside Court Eastbound					Int. Total
	Right	Thru	UTrn	Peds	App. Total	Thru	Left	UTrn	Peds	App. Total	Right	Left	UTrn	Peds	App. Total	
Peak Hour Analysis From 12:00 PM to 06:45 PM - Peak 1 of 1																
Peak Hour for Entire Intersection Begins at 04:30 PM																
04:30 PM	4	79	0	0	83	123	1	0	0	124	3	2	0	0	5	212
04:45 PM	4	97	0	0	101	118	3	0	0	121	5	1	0	0	6	228
05:00 PM	3	73	0	0	76	148	8	0	0	156	6	0	0	0	6	238
05:15 PM	1	89	0	0	90	112	8	0	0	120	5	0	0	0	5	215
Total Volume	12	338	0	0	350	501	20	0	0	521	19	3	0	0	22	893
% App. Total	3.4	96.6	0	0		96.2	3.8	0	0		86.4	13.6	0	0		
PHF	.750	.871	.000	.000	.866	.846	.625	.000	.000	.835	.792	.375	.000	.000	.917	.938

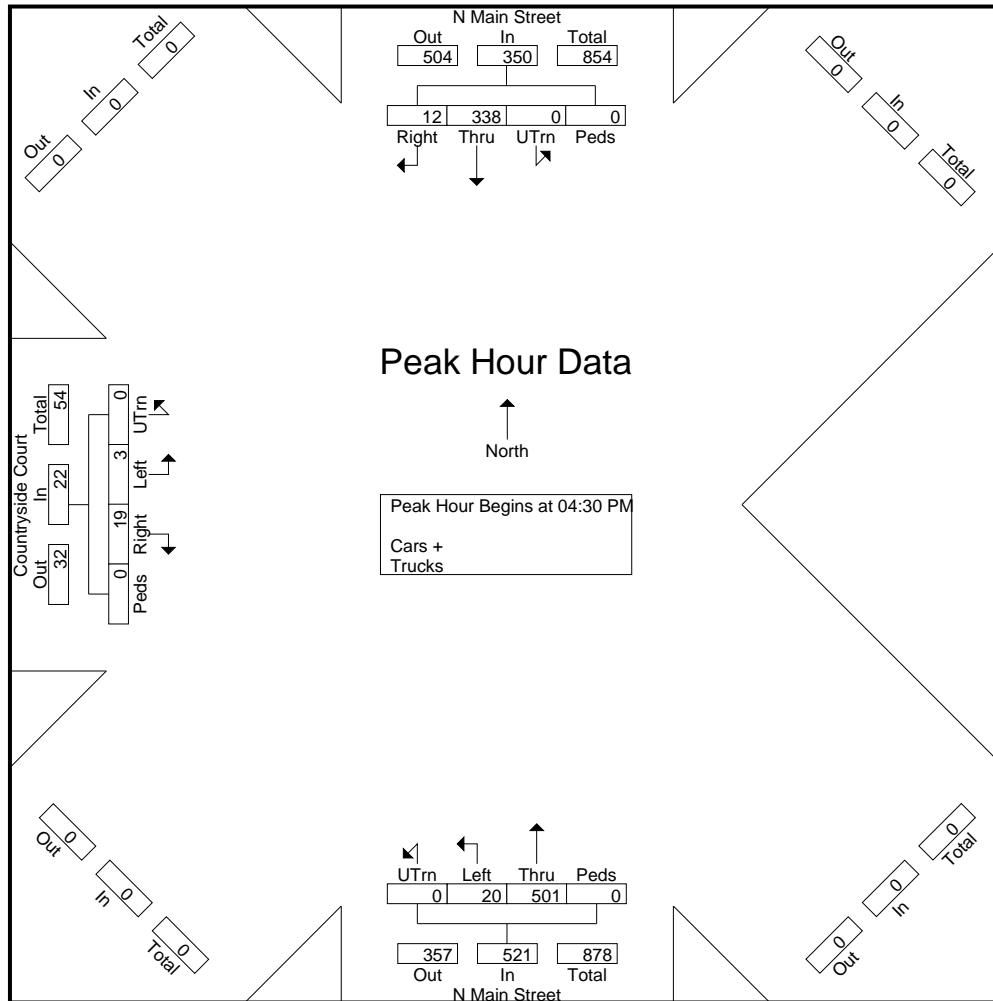



TRAFFIC DATA COLLECTION

File Name : Blacksburg(N Main Street and Countryside Court) 10-19
 Site Code :
 Start Date : 10/19/2022
 Page No : 1

Groups Printed- Cars + - Trucks

Start Time	N Main Street Southbound				N Main Street Northbound				Countryside Court Eastbound				Int. Total
	Right	Thru	Peds	App. Total	Thru	Left	Peds	App. Total	Right	Left	Peds	App. Total	
07:00 AM	0	67	0	67	31	2	0	33	1	0	0	1	101
07:15 AM	0	88	2	90	15	3	0	18	2	1	0	3	111
07:30 AM	2	147	0	149	17	1	0	18	4	1	0	5	172
07:45 AM	2	119	0	121	17	0	0	17	5	0	0	5	143
Total	4	421	2	427	80	6	0	86	12	2	0	14	527
08:00 AM	2	79	0	81	29	3	0	32	5	2	0	7	120
08:15 AM	2	74	0	76	29	4	0	33	3	1	0	4	113
08:30 AM	1	124	0	125	47	1	0	48	9	1	0	10	183
08:45 AM	1	124	0	125	47	1	0	48	4	5	0	9	182
Total	6	401	0	407	152	9	0	161	21	9	0	30	598
09:00 AM	1	89	0	90	38	3	0	41	5	3	0	8	139
09:15 AM	0	88	0	88	35	1	0	36	0	1	0	1	125
09:30 AM	0	66	0	66	37	1	0	38	4	0	2	6	110
09:45 AM	2	66	2	70	38	2	0	40	5	0	0	5	115
Total	3	309	2	314	148	7	0	155	14	4	2	20	489
10:00 AM	2	47	1	50	30	2	0	32	2	2	0	4	86
10:15 AM	1	44	0	45	39	2	0	41	2	0	0	2	88
10:30 AM	0	55	0	55	35	2	0	37	3	0	0	3	95
10:45 AM	1	64	0	65	31	3	0	34	1	1	0	2	101
Total	4	210	1	215	135	9	0	144	8	3	0	11	370
11:00 AM	1	70	0	71	38	2	0	40	2	1	0	3	114
11:15 AM	2	93	0	95	43	2	0	45	2	0	0	2	142
11:30 AM	3	65	0	68	54	5	0	59	1	0	0	1	128
11:45 AM	1	63	0	64	64	2	0	66	3	1	0	4	134
Total	7	291	0	298	199	11	0	210	8	2	0	10	518
12:00 PM	3	64	0	67	49	4	0	53	3	0	0	3	123
12:15 PM	1	61	0	62	50	5	0	55	4	0	0	4	121
12:30 PM	1	52	0	53	60	1	0	61	3	0	0	3	117
12:45 PM	1	67	0	68	37	4	0	41	1	1	0	2	111
Total	6	244	0	250	196	14	0	210	11	1	0	12	472
01:00 PM	2	54	0	56	36	0	0	36	5	0	0	5	97
01:15 PM	3	51	0	54	45	2	0	47	4	0	0	4	105
01:30 PM	2	54	0	56	52	0	0	52	3	0	0	3	111
01:45 PM	3	53	0	56	40	1	0	41	6	0	0	6	103
Total	10	212	0	222	173	3	0	176	18	0	0	18	416
02:00 PM	2	56	0	58	37	3	0	40	3	0	0	3	101
02:15 PM	0	42	0	42	42	4	0	46	3	0	0	3	91
02:30 PM	3	47	0	50	60	3	0	63	7	2	0	9	122



TRAFFIC DATA COLLECTION

File Name : Blacksburg(N Main Street and Countryside Court) 10-19
 Site Code :
 Start Date : 10/19/2022
 Page No : 2

Groups Printed- Cars + - Trucks

Start Time	N Main Street Southbound				N Main Street Northbound				Countryside Court Eastbound				Int. Total
	Right	Thru	Peds	App. Total	Thru	Left	Peds	App. Total	Right	Left	Peds	App. Total	
02:45 PM	1	46	0	47	56	1	0	57	4	1	0	5	109
Total	6	191	0	197	195	11	0	206	17	3	0	20	423
03:00 PM	2	65	0	67	67	2	0	69	2	0	0	2	138
03:15 PM	1	73	0	74	64	2	0	66	3	1	0	4	144
03:30 PM	0	59	0	59	101	3	0	104	1	0	0	1	164
03:45 PM	3	50	2	55	81	2	0	83	5	1	0	6	144
Total	6	247	2	255	313	9	0	322	11	2	0	13	590
04:00 PM	2	70	1	73	93	4	0	97	5	1	0	6	176
04:15 PM	2	60	0	62	98	2	0	100	3	1	0	4	166
04:30 PM	3	65	0	68	101	3	0	104	3	0	0	3	175
04:45 PM	4	90	0	94	78	3	0	81	4	2	0	6	181
Total	11	285	1	297	370	12	0	382	15	4	0	19	698
05:00 PM	3	79	0	82	152	6	0	158	6	1	0	7	247
05:15 PM	2	83	0	85	110	5	0	115	7	0	1	8	208
05:30 PM	4	77	0	81	110	6	0	116	4	1	0	5	202
05:45 PM	4	92	0	96	94	4	0	98	5	0	0	5	199
Total	13	331	0	344	466	21	0	487	22	2	1	25	856
06:00 PM	3	61	0	64	89	2	0	91	3	1	0	4	159
06:15 PM	3	55	0	58	74	5	0	79	4	1	0	5	142
06:30 PM	1	63	0	64	63	3	0	66	2	0	0	2	132
06:45 PM	1	63	0	64	53	7	0	60	4	2	0	6	130
Total	8	242	0	250	279	17	0	296	13	4	0	17	563
Grand Total	84	3384	8	3476	2706	129	0	2835	170	36	3	209	6520
Apprch %	2.4	97.4	0.2		95.4	4.6	0		81.3	17.2	1.4		
Total %	1.3	51.9	0.1	53.3	41.5	2	0	43.5	2.6	0.6	0	3.2	
Cars +	76	3338	8	3422	2680	124	0	2804	161	35	3	199	6425
% Cars +	90.5	98.6	100	98.4	99	96.1	0	98.9	94.7	97.2	100	95.2	98.5
Trucks	8	46	0	54	26	5	0	31	9	1	0	10	95
% Trucks	9.5	1.4	0	1.6	1	3.9	0	1.1	5.3	2.8	0	4.8	1.5



TRAFFIC DATA COLLECTION

File Name : Blacksburg(N Main Street and Countryside Court) 10-19
 Site Code :
 Start Date : 10/19/2022
 Page No : 3

Start Time	N Main Street Southbound				N Main Street Northbound				Countryside Court Eastbound				Int. Total
	Right	Thru	Peds	App. Total	Thru	Left	Peds	App. Total	Right	Left	Peds	App. Total	
Peak Hour Analysis From 07:00 AM to 08:45 AM - Peak 1 of 1													
Peak Hour for Entire Intersection Begins at 08:00 AM													
08:00 AM	2	79	0	81	29	3	0	32	5	2	0	7	120
08:15 AM	2	74	0	76	29	4	0	33	3	1	0	4	113
08:30 AM	1	124	0	125	47	1	0	48	9	1	0	10	183
08:45 AM	1	124	0	125	47	1	0	48	4	5	0	9	182
Total Volume	6	401	0	407	152	9	0	161	21	9	0	30	598
% App. Total	1.5	98.5	0		94.4	5.6	0		70	30	0		
PHF	.750	.808	.000	.814	.809	.563	.000	.839	.583	.450	.000	.750	.817

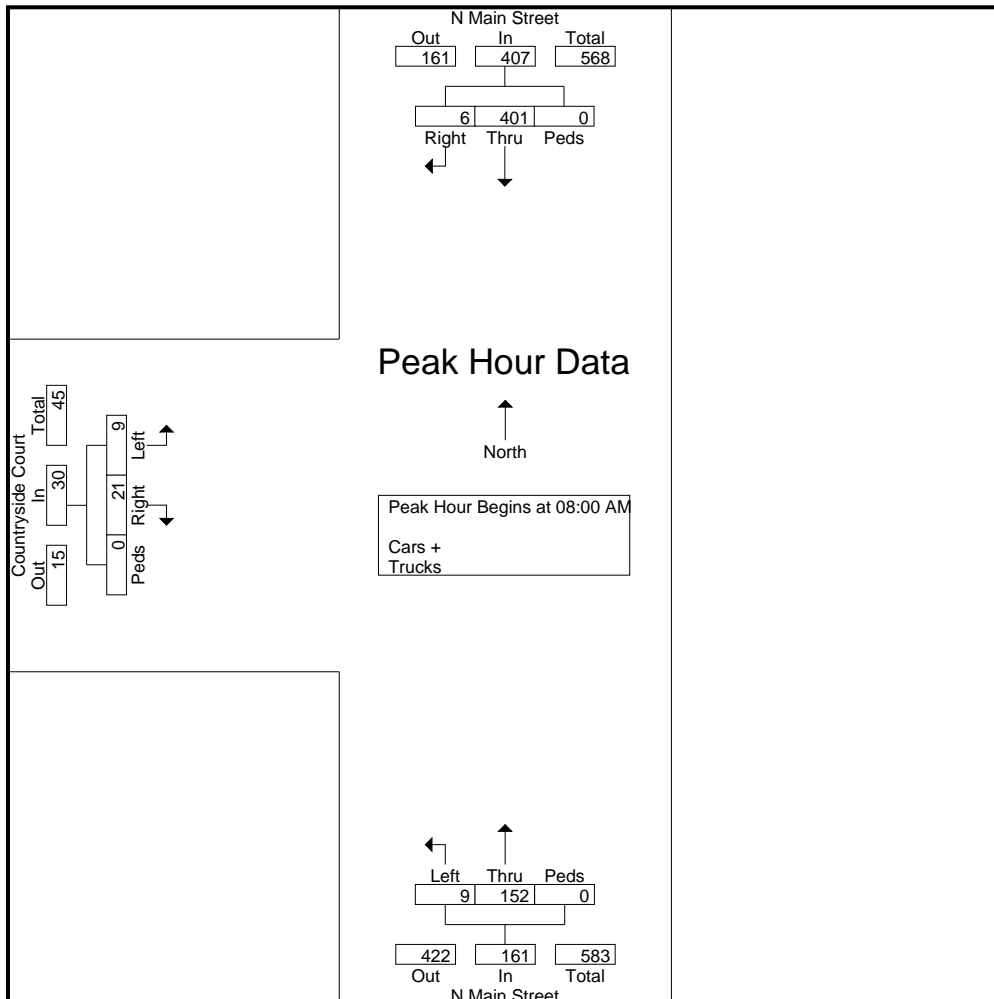



TRAFFIC DATA COLLECTION

File Name : Blacksburg(N Main Street and Countryside Court) 10-19
 Site Code :
 Start Date : 10/19/2022
 Page No : 4

Start Time	N Main Street Southbound				N Main Street Northbound				Countryside Court Eastbound				Int. Total
	Right	Thru	Peds	App. Total	Thru	Left	Peds	App. Total	Right	Left	Peds	App. Total	
Peak Hour Analysis From 04:00 PM to 05:45 PM - Peak 1 of 1													
Peak Hour for Entire Intersection Begins at 05:00 PM													
05:00 PM	3	79	0	82	152	6	0	158	6	1	0	7	247
05:15 PM	2	83	0	85	110	5	0	115	7	0	1	8	208
05:30 PM	4	77	0	81	110	6	0	116	4	1	0	5	202
05:45 PM	4	92	0	96	94	4	0	98	5	0	0	5	199
Total Volume	13	331	0	344	466	21	0	487	22	2	1	25	856
% App. Total	3.8	96.2	0		95.7	4.3	0		88	8	4		
PHF	.813	.899	.000	.896	.766	.875	.000	.771	.786	.500	.250	.781	.866

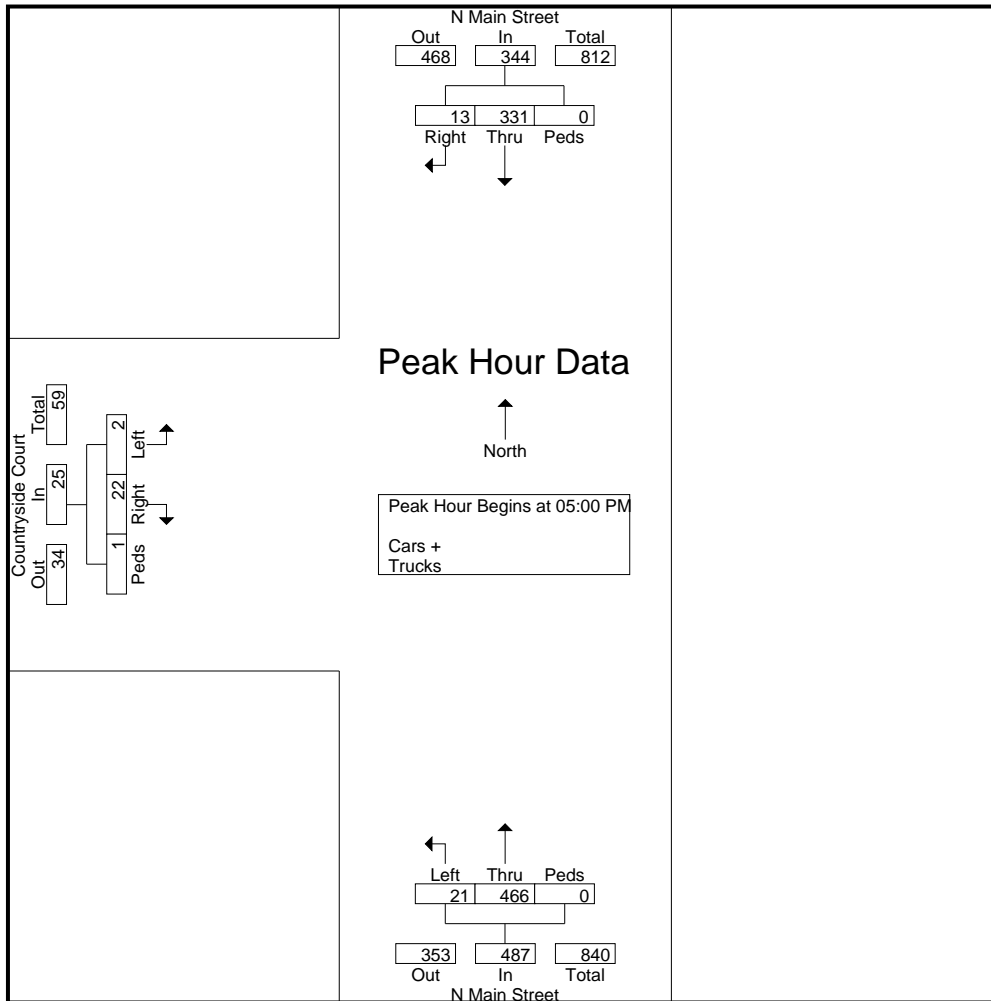

SCOPING DOCUMENTATION



PRE-SCOPE OF WORK MEETING FORM

Information on the Project Traffic Impact Analysis Base Assumptions

The applicant is responsible for entering the relevant information and submitting the form to VDOT and the locality no less than three (3) business days prior to the meeting. If a form is not received by this deadline, the scope of work meeting may be postponed.

Contact Information			
Consultant Name: Tele: E-mail:	Ramey Kemp & Associates, Inc. - Chase Smith, P.E. (336) 725-5470 csmith@rameykemp.com		
Developer/Owner Name: Tele: E-mail:	CC&B Development, LLC / Ian Friend ifriend@sasbuilders.com		
Project Information			
Project Name:	Northside Subdivision	Locality/County:	Town of Blacksburg
Project Location: (Attach regional and site specific location map)	Refer to Figure 1		
Submission Type	Comp Plan <input type="checkbox"/>	Rezoning <input type="checkbox"/>	Site Plan <input checked="" type="checkbox"/> Subd Plat <input type="checkbox"/>
Project Description: (Including details on the land use, acreage, phasing, access location, etc. Attach additional sheet if necessary)	Preliminary development plan includes 51 single-family lots		
Proposed Use(s): (Check all that apply; attach additional pages as necessary)	Residential <input checked="" type="checkbox"/>	Commercial <input type="checkbox"/>	Mixed Use <input type="checkbox"/> Other <input type="checkbox"/>
	Residential Uses(s) Number of Units: 51 ITE LU Code(s): 210 _____ _____ Commercial Use(s) ITE LU Code(s): _____ _____ _____ Square Ft or Other Variable: _____	_____ _____ _____ Other Use(s) ITE LU Code(s): _____ _____ _____ Independent Variable(s): _____ _____ _____	
Total Peak Hour Trip Projection:	Less than 100 <input checked="" type="checkbox"/>	100 – 499 <input type="checkbox"/>	500 – 999 <input type="checkbox"/> 1,000 or more <input type="checkbox"/>

It is important for the applicant to provide sufficient information to county and VDOT staff so that questions regarding geographic scope, alternate methodology, or other issues can be answered at the scoping meeting.

Traffic Impact Analysis Assumptions			
Study Period	Existing Year: 2022	Build-out Year:	Design Year: 2027
Study Area Boundaries (Attach map)	North: See Figure 1	South:	
	East:	West:	
External Factors That Could Affect Project (Planned road improvements, other nearby developments)	Whipple Drive Townhomes, if development is approved (estimated build-out is 2023)		
Consistency With Comprehensive Plan (Land use, transportation plan)			
Available Traffic Data (Historical, forecasts)	N Main Street - 6,500 ADT 2019 Givens Lane - 1,500 ADT 2019		
Trip Distribution (Attach sketch)	Road Name: See Figure 2	Road Name:	
	Road Name:	Road Name:	
Annual Vehicle Trip Growth Rate:	2.5%	Peak Period for Study (check all that apply)	<input checked="" type="checkbox"/> AM <input checked="" type="checkbox"/> PM <input type="checkbox"/> SAT
		Peak Hour of the Generator	
Study Intersections and/or Road Segments (Attach additional sheets as necessary)	1.Givens Lane and Progress Street	6.	
	2.Givens Lane and Carroll Drive	7.	
	3.Givens Lane/Mountain Breeze Drive and N Main Street	8.	
	4.N Main Street and Countryside Court	9.	
	5.	10.	
Trip Adjustment Factors	Internal allowance: <input type="checkbox"/> Yes <input checked="" type="checkbox"/> No Reduction: _____% trips	Pass-by allowance: <input type="checkbox"/> Yes <input checked="" type="checkbox"/> No Reduction: _____% trips	
	<input checked="" type="checkbox"/> Synchro <input type="checkbox"/> HCS (v.2000/+) <input checked="" type="checkbox"/> aaSIDRA <input type="checkbox"/> CORSIM <input checked="" type="checkbox"/> Other SimTraffic		
Traffic Signal Proposed or Affected (Analysis software to be used, progression speed, cycle length)	Synchro / SimTraffic 11 will be used to analyze LOS, delay, and queueing at the study intersections. Sidra will be utilized at all round-a-bouts		

It is important for the applicant to provide sufficient information to county and VDOT staff so that questions regarding geographic scope, alternate methodology, or other issues can be answered at the scoping meeting.

Improvement(s) Assumed or to be Considered	The need for turn lanes and other off-site improvements will be determined based on the results of the TIA.
Background Traffic Studies Considered	Whipple Drive Townhomes, if development is approved (estimated build-out is 2023)
Plan Submission	<input type="checkbox"/> Master Development Plan (MDP) <input checked="" type="checkbox"/> Generalized Development Plan (GDP) <input type="checkbox"/> Preliminary/Sketch Plan <input type="checkbox"/> Other Plan type (Final Site, Subd. Plan)
Additional Issues to be Addressed	<input checked="" type="checkbox"/> Queuing analysis <input type="checkbox"/> Actuation/Coordination <input type="checkbox"/> Weaving analysis <input type="checkbox"/> Merge analysis <input checked="" type="checkbox"/> Bike/Ped Accommodations <input checked="" type="checkbox"/> Intersection(s) <input type="checkbox"/> TDM Measures <input checked="" type="checkbox"/> Other SWA at N Main Street/Givens Lane

NOTES on ASSUMPTIONS:

The TIA will include three analysis scenarios:

- Existing (2022) Traffic Conditions
- No-Build(2027) Traffic Conditions
- Build (2027) Traffic Conditions

- New counts will be collected at all study intersections, with the exception of Givens Lane/N Main Street (recent counts from 4/12/22 and 4/13/22 will be utilized). New traffic counts will be taken 10/18/22-10/19/22. Traffic counts will be conducted over the course of two days during 12 periods which encapsulate the AM and PM peak hour windows. Pedestrian and bicycle counts will also be collected at all study intersections.

-RKA and the Town have analyzed area growth rates to verify that 2.5% is applicable (coordinated and approved by the Town for the adjacent development in the area)

SIGNED: _____ DATE: _____
Applicant or Consultant

PRINT NAME: _____
Applicant or Consultant

It is important for the applicant to provide sufficient information to county and VDOT staff so that questions regarding geographic scope, alternate methodology, or other issues can be answered at the scoping meeting.



BALZER & ASSOCIATES
PLANNERS / ARCHITECTS
ENGINEERS / SURVEYORS

Roanoke / Richmond
New River Valley
Shenandoah Valley
www.balzer.cc
80 College Street
Suite H
Christiansburg, VA 24073
540.381.4290

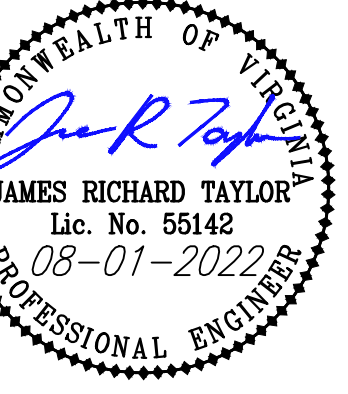

NORTHSIDE PARK - REVISED SECTION XII
PRELIMINARY PLAT
OVERALL LAYOUT

MOUNT LABOR MAGISTERIAL DISTRICT
TOWN OF BLACKSBURG, VIRGINIA

DRAWN BY: SJW
DESIGNED BY: SJW
CHECKED BY: JRT
DATE: 8/1/2022
SCALE: AS SHOWN
REVISIONS:

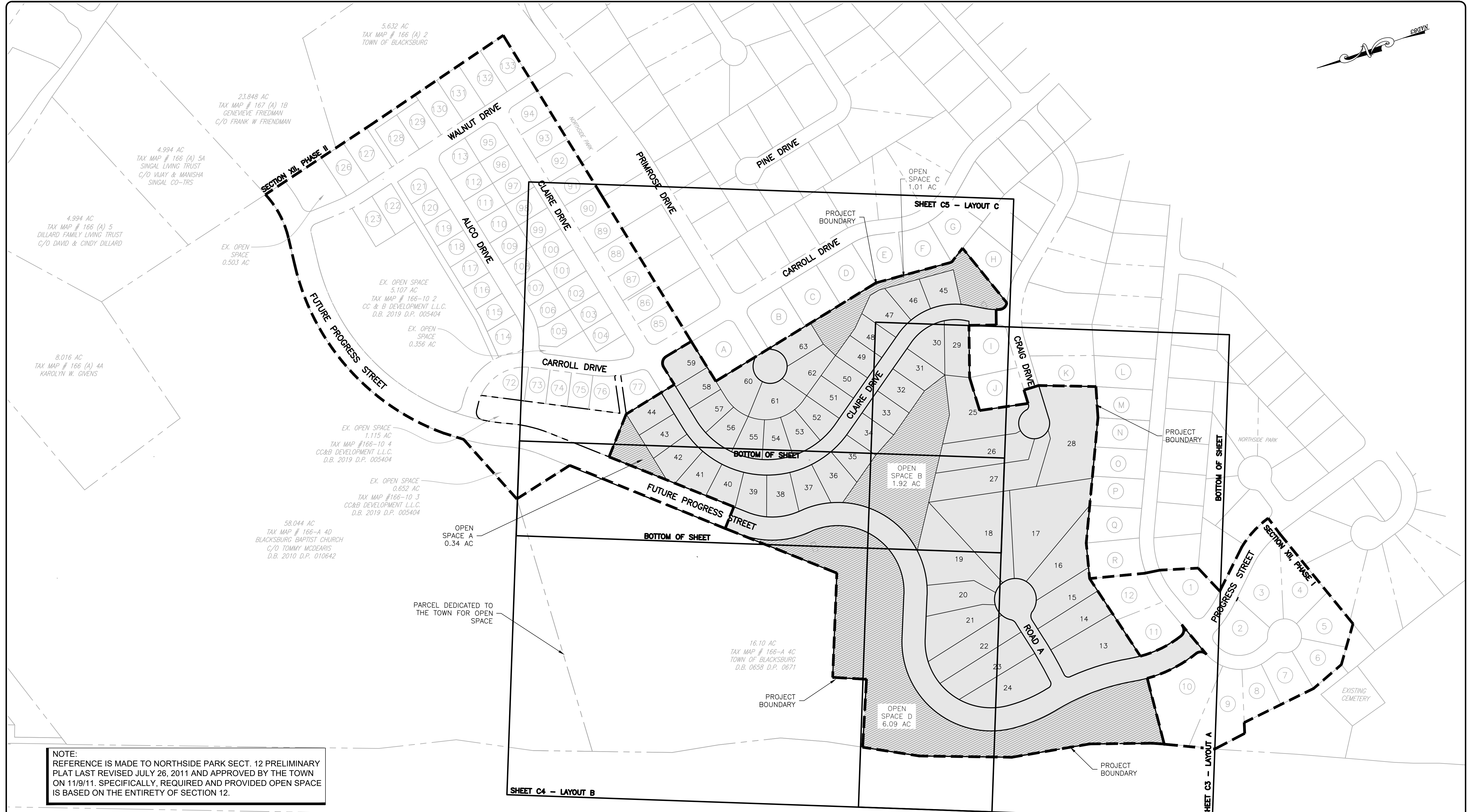
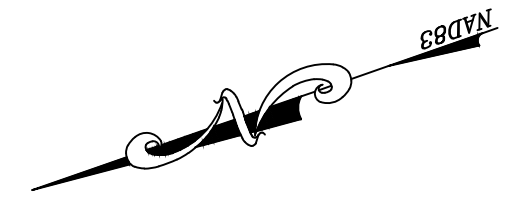

NOTE:
REFERENCE IS MADE TO NORTHSIDE PARK SECT. 12 PRELIMINARY PLAT LAST REVISED JULY 26, 2011 AND APPROVED BY THE TOWN ON 11/9/11. SPECIFICALLY, REQUIRED AND PROVIDED OPEN SPACE IS BASED ON THE ENTIRETY OF SECTION 12.

ADJACENT PROPERTY OWNERS:

- | | | | | | | | | | | | | | | | | | | | | | |
|---|---|--|---|---|---|--|--|---|--|---|---|---|---|--|---|---|---|---|--|--|---|
| <p>⑩ TRAVIS AND MEGAN ESCHENMANN
TAX #166-17 10
D.B. 2008 PG. 011143
P.B. 0025 PG. 0108
ZONING: R-4</p> | <p>① SCOTTIE AND BILLIE WYATT
TAX #166-17 11
D.B. 2017 PG. 006588
P.B. 0025 PG. 108
ZONING: R-4</p> | <p>⑫ KIRK AND MELISSA CAMERON
TAX #166-17 12
D.B. 2017 PG. 006588
P.B. 0025 PG. 0108
ZONING: R-4</p> | <p>⑪⑦ CC&B DEVELOPMENT LLC
TAX #166-10 77
2019 PG. 005404
INST # - 2019004424
ZONING: R-4</p> | <p>① MOHAMED KHALED HASSOUNA AND ALI DINA FATH
TAX #166-1 10
D.B. 2016 PG. 001057
INST. #2016001057
ZONING: R-4</p> | <p>② GREGORY B IRWIN
TAX #166-1 9
D.B. 2020 PG. 008205
P.B. 0006 PG. 0104
ZONING: R-4</p> | <p>③ HALLAUER LIVING TRUST
C/O WILLIAM L HALLAUER JR CO-TRS
TAX #166-1 8
D.B. 2014 PG. 008216
P.B. 0006 PG. 0104
ZONING: R-4</p> | <p>④ HAO SHI AND JIE RONG
TAX #166-1 7
D.B. 2013 PG. 007550
P.B. 0006 PG. 0104
ZONING: R-4</p> | <p>⑤ JESS JONES AND KATHLEEN GILBERT
TAX #166-1 6
D.B. 2012 PG. 009140
P.B. 0006 PG. 0104
ZONING: R-4</p> | <p>⑥ WILLIAM AND TERESA PRICE
TAX #166-1 5
D.B. 2006 PG. 003777
P.B. 0006 PG. 0104
ZONING: R-4</p> | <p>⑦ ARTHUR MOOK AND JENNIFER MORGAN
TAX #166-1 4
D.B. 2014 PG. 004029
P.B. 0847 PG. 0616
ZONING: R-4</p> | <p>⑧ JOSEPH AND LESLIE PARADISO
TAX #166-1 01
D.B. 2013 PG. 007550
P.B. 0016 PG. 0692
ZONING: R-4</p> | <p>⑨ ADAM AND KERRI EDWARDS
TAX #166-7 10
D.B. 2016 PG. 003014
P.B. 0016 PG. 0692
ZONING: R-4</p> | <p>⑩ GERARD AND JANICE TESTI
TAX #166-1 5
D.B. 2010 PG. 005951
P.B. 0016 PG. 0692
ZONING: R-4</p> | <p>⑪ ROBERT AND GAYLE KIRBY
TAX #166-10 78
D.B. 0991 PG. 0195
P.B. 0847 PG. 0692
ZONING: R-4</p> | <p>⑫ SAGHAN MAROOF
TAX #166-7 9
D.B. 1039 PG. 0149
P.B. 1039 PG. 0152
ZONING: R-4</p> | <p>⑬ CHRISTOPHER SHIVELY AND RICHARD SHIELD
TAX #166-7 10
D.B. 2002 PG. 005787
P.B. 0015 PG. 0195
ZONING: R-4</p> | <p>⑭ MING XU AND PING YAN
TAX #166-9 18
D.B. 2004 PG. 005118
P.B. 0862 PG. 0005
ZONING: R-4</p> | <p>⑮ PETER WILLENSTEIN AND HO SOOKHAN
TAX #166-4 19
D.B. 0780 PG. 0488
P.B. 0015 PG. 0370
ZONING: R-4</p> | <p>⑯ DAVID R BEVAN III AND PATRICE ERNST BEVAN
TAX #166-8 20
D.B. 1008 PG. 0049
P.B. 1008 PG. 0051
ZONING: R-4</p> | <p>⑰ STEVEN AND HOLLY ROSS
TAX #166-9 21
D.B. 2006 PG. 006622
P.B. 0015 PG. 0370
ZONING: R-4</p> | <p>⑱ MING XU AND PING YAN
TAX #166-9 22
D.B. 2010 PG. 005172
P.B. 0015 PG. 0370
ZONING: R-4</p> |
|---|---|--|---|---|---|--|--|---|--|---|---|---|---|--|---|---|---|---|--|--|---|

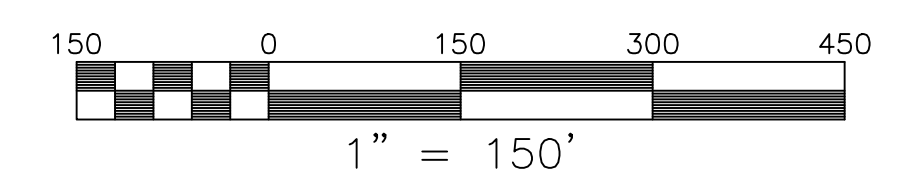

APPROVAL BLOCK	
BLACKSBURG TOWN PLANNER	DATE
BLACKSBURG TOWN ENGINEER	DATE

J:\2020\24220049\01 NORTHSIDE PARK-SECTION XII\NORTHSIDE PRELIMINARY PLAT.dwg PLOTTED: 8/1/2022 1:38:42 PM

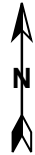
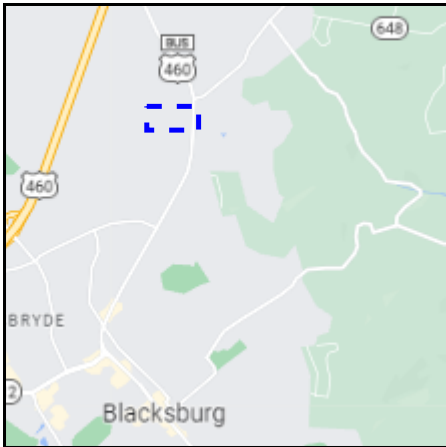

LEGEND

-  Study Intersection
-  Proposed Interconnectivity to the Site
-  Study Area



Northside Subdivision
Blacksburg, VA

Site Location Map

Scale: Not to Scale Figure 1

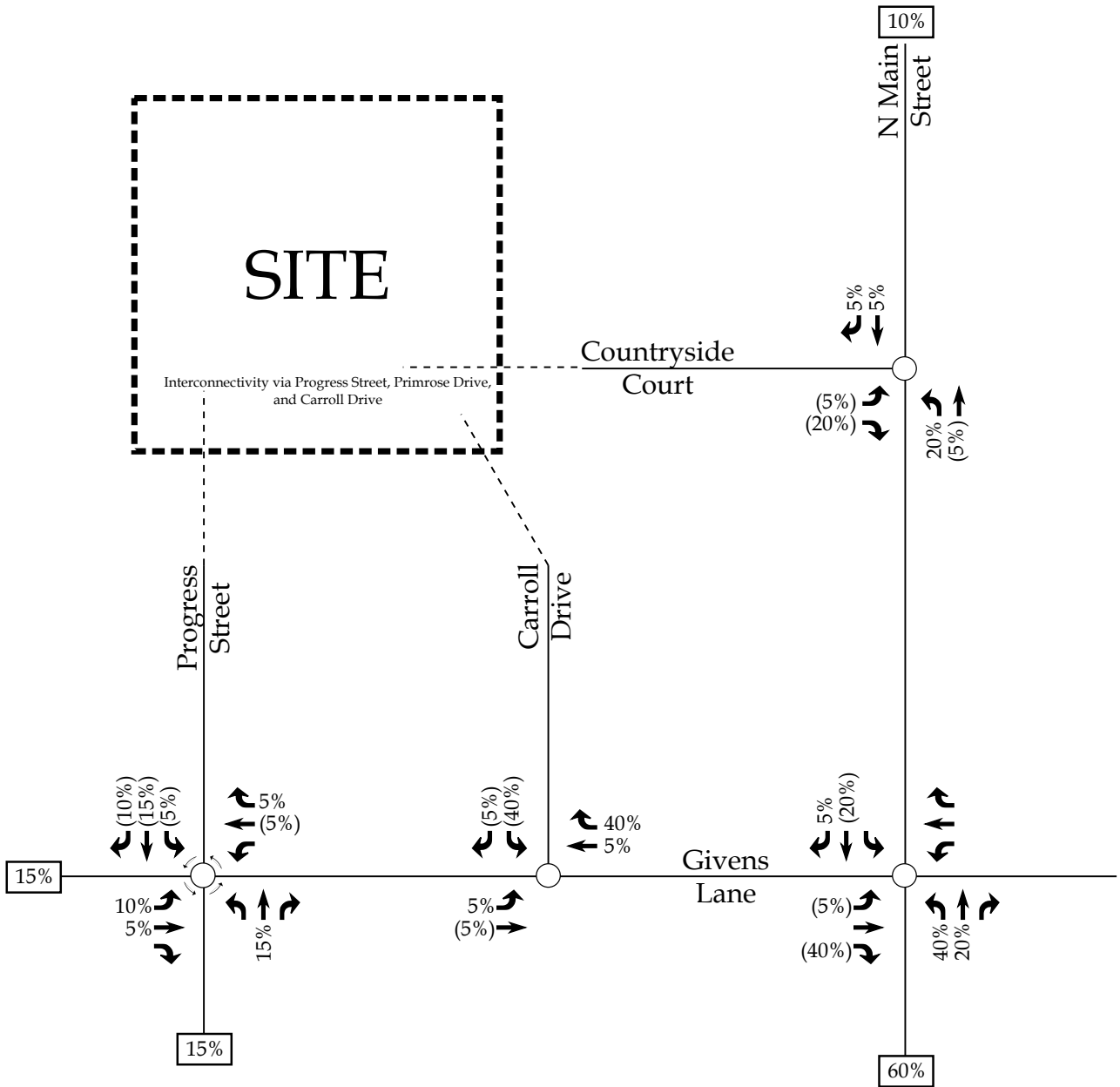

Northside Subdivision
Blacksburg, VA

Site Trip Distribution

Scale: Not to Scale

Figure 8

Anna Irby

From: Gretchen Merix <gmerix@balzer.cc>
Sent: Wednesday, November 2, 2022 7:19 AM
To: Chase Smith; Steve Semones
Cc: Anna Irby
Subject: RE: Northside Subdivision - Blacksburg Scoping Email
Attachments: Sheet C5.pdf; The Summit Traffic Volumes.pdf; SHEET C4.pdf

Follow Up Flag: Follow up
Flag Status: Completed

Chase,

The Summit Townhomes project is located at 1820 N. Main Street will have 44 units with 131 beds at final buildout. I've attached the traffic calculations we included with our CUP submittal and the overall layout plan.

Hayes Colony is located at 101 Mount Tabor Road (at the intersection of N. Main and Mt Tabor). It will have 6 units with 18 beds. I've attached the layout plan for this one as well.

Hope this helps...let me know if you need more information.

Thanks,

Gretchen L. Merix, PE, M.ASCE
Project Manager

Balzer & Associates

Envisioning tomorrow. Designing today.

Planners / Architects / Engineers / Surveyors

Roanoke / Richmond / New River Valley / Shenandoah Valley
80 College Street, Suite H, Christiansburg, VA, 24073 / p 540.381.4290
www.balzer.cc

The materials attached to this communication are the proprietary property of Balzer and Associates, Inc. ("Balzer") and are protected by copyright and other intellectual property rights. No portion of these materials may be used or relied upon by any person or entity other than the recipient of this communication without prior written permission from Balzer.

This email may contain electronic data. Electronic data is defined to include, but not specifically limited to: files, data, plans, specifications, reports, documents, or other information recorded on or transmitted as electronic media, including but not limited to computer-aided design ("CAD") files and documents. Electronic data transmitted via email is subject to undetectable alteration caused by or resulting from, among other causes, transmission, conversion, media degradation, software error, or human alteration. Accordingly, all electronic data is provided to the parties for informational purposes only and not as an end product or a record document. Any reliance thereon is deemed to be unreasonable and unenforceable. Transfer of the electronic data does not grant, authorize, convey, or transfer any license of any kind. Balzer makes no representation as to the durability of the electronic data or the medium in or on which it is transferred. The signed and/or stamped original and/or hard copy of the original of Balzer's Instruments of Service are the only true documents of record. Nothing contained herein alters the terms of any other Agreements between the Owner and/or Subconsultant and Balzer.

©2021 Balzer and Associates, Inc. All rights reserved.

From: Chase Smith <csmith@rameykemp.com>
Sent: Tuesday, November 1, 2022 5:02 PM
To: Steve Semones <ssemones@balzer.cc>
Cc: Gretchen Merix <gmerix@balzer.cc>; Anna Irby <airby@rameykemp.com>
Subject: FW: Northside Subdivision - Blacksburg Scoping Email

Hey there Steve,

See Joshua's email below. Sounds like we need some info from you on a few developments in order to include in our Northside Subdivision traffic study.

Thanks!

Chase Smith, PE
Traffic Engineering Project Manager

D 336 714 0112 | T 336 725 5470 | C 336 813 9289

rameykemp.com

From: Joshua Middleton <JMiddleton@blacksburg.gov>
Sent: Tuesday, November 1, 2022 4:55 PM
To: Anna Irby <airby@rameykemp.com>
Cc: Chase Smith <csmith@rameykemp.com>
Subject: RE: Northside Subdivision - Blacksburg Scoping Email

Anna,

We were able to review the scoping document this afternoon and find it largely acceptable. The only area we need you to tweak is with regard to the background Traffic Studies Considerations and External Factors. In addition to the Whipple Dr. Townhomes project that may be approved shortly, there are also two developments currently under construction immediately adjacent on North main St. They are the Charter House/Hayes Colony Duplexes and The Summit (1820) Townhomes. Both projects were designed by Blazer and Associates so please get with Steve Semones to get all relevant volume, layout and distribution data.

Please let me know if you need anything further as you continue the analysis.

Sincerely,

Joshua P. Middleton
Town Engineer
400 South Main Street
Blacksburg, VA 24060
540-443-1353
JMiddleton@blacksburg.gov

From: Anna Irby <airby@rameykemp.com>
Sent: Tuesday, October 25, 2022 9:01 AM
To: Joshua Middleton <JMiddleton@blacksburg.gov>
Cc: Chase Smith <csmith@rameykemp.com>
Subject: Northside Subdivision - Blacksburg Scoping Email

CAUTION: This email originated from outside your organization. Exercise caution when opening attachments or clicking links, especially from unknown senders.

Good morning Joshua,

Chase and I were recently contacted by Steve Semones about a new residential development located west of N Main Street and north of Givens Lane. The development is not proposing any new driveways but interconnectivity through

Progress Street, Carroll Drive, and Primrose Drive. It is our understanding that you have had coordination with Steve in regards to the study area for the TIA. We have pulled together the scoping document based on that information and study parameters that were approved for the Whipple Drive Townhome development we completed recently in the same area.

Please review and let us know if there are any questions or comments regarding the scope of work.

Thank you,

—
Anna Irby
Traffic Engineering Associate
D 704 220 6864 | T 919 872 5115



VDOT TURN LANE WARRANTS

WARRANT FOR LEFT-TURN STORAGE LANES ON TWO-LANE HIGHWAYS

Main Street No-Build Peak Hour Turn Lane Warrants

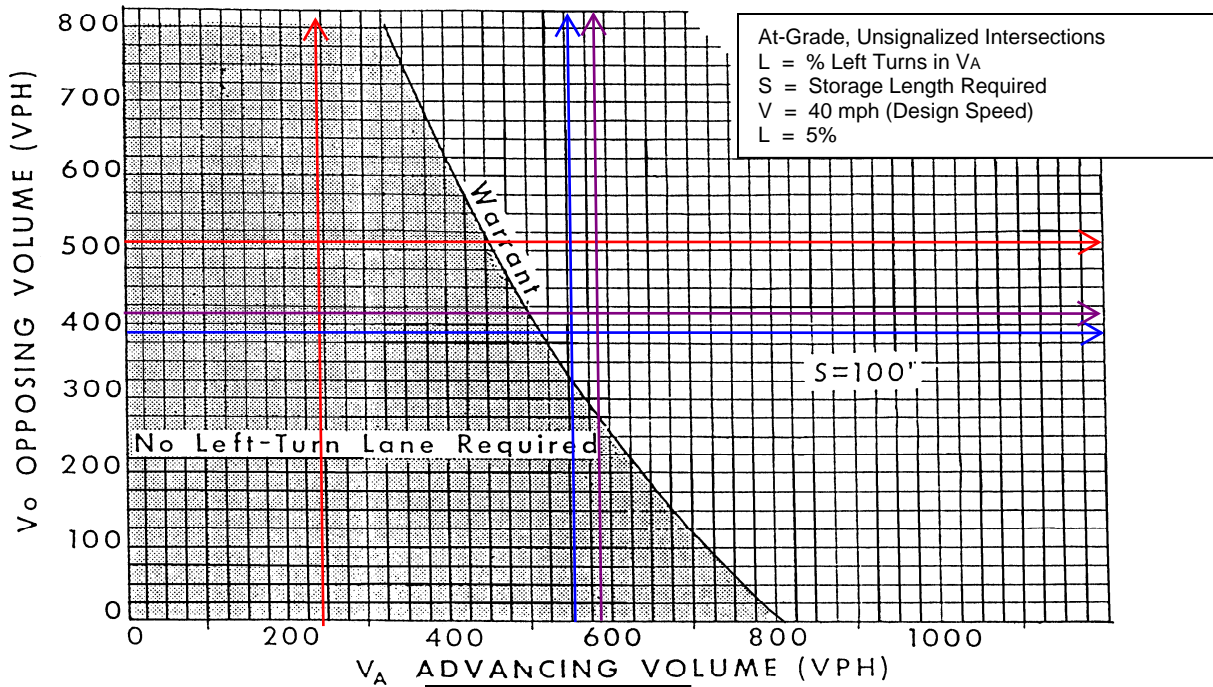

FIGURE 3-4

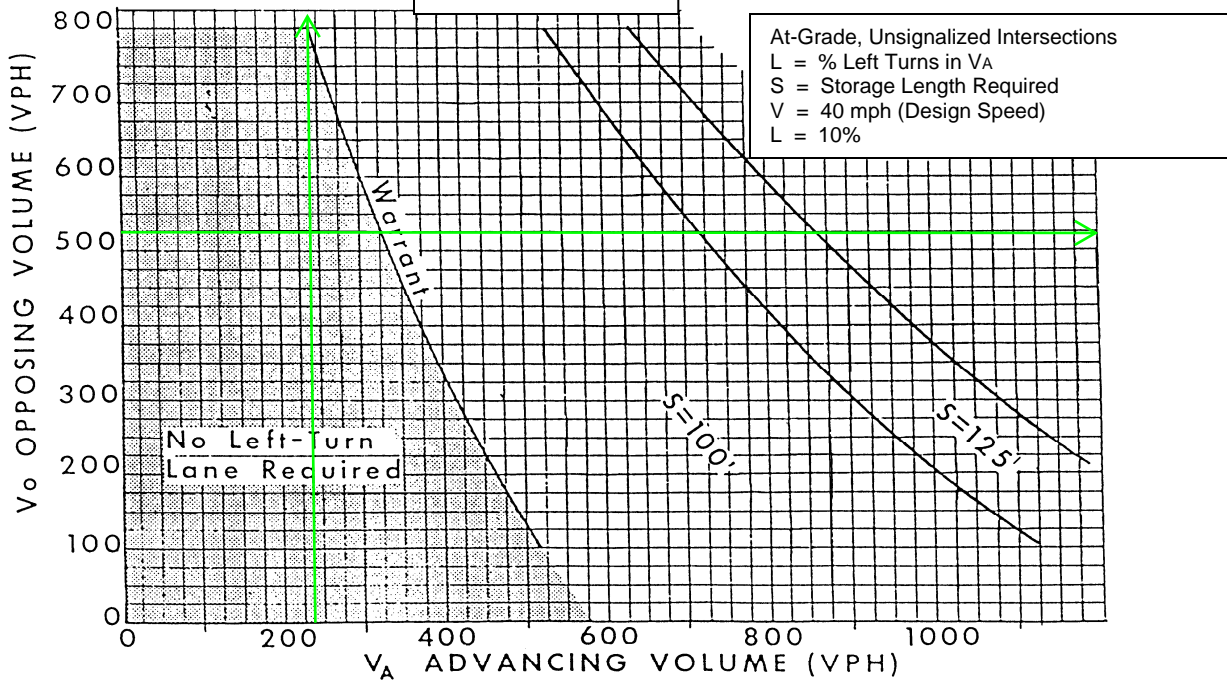
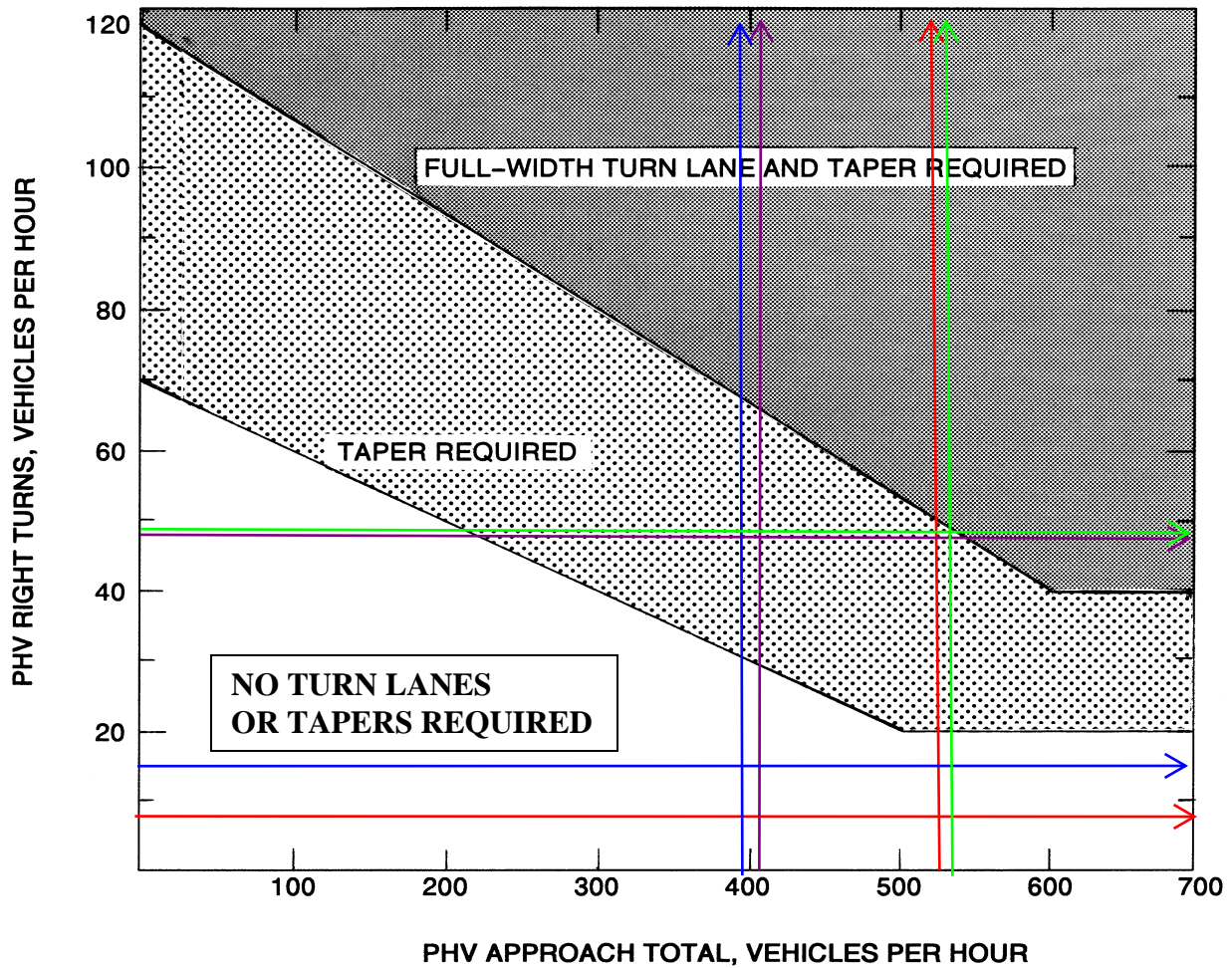

FIGURE 3-5

Legend	
N Main & Countryside NBL AM Peak	(Red)
N Main & Countryside NBL PM Peak	(Blue)
Main & Givens NBL AM Peak	(Green)
Main & Givens NBL PM Peak	(Purple)



Appropriate Radius required at all Intersections and Entrances (Commercial or Private).

LEGEND

PHV - Peak Hour Volume (also Design Hourly Volume equivalent)

Adjustment for Right Turns

For posted speeds at or under 45 mph, PHV right turns > 40, and PHV total < 300.

Adjusted right turns = PHV Right Turns - 20

If PHV is not known use formula: $PHV = ADT \times K \times D$

K = the percent of AADT occurring in the peak hour

D = the percent of traffic in the peak direction of flow

Note: An average of 11% for K x D will suffice.

FIGURE 3-23 GUIDELINES FOR RIGHT TURN TREATMENT (2-LANE HIGHWAY)

Legend
N Main & Countryside SBR AM Peak
N Main & Countryside SBR PM Peak
Main & Givens SBR AM Peak
Main & Givens SBR PM Peak

CAPACITY ANALYSIS CALCULATIONS
N MAIN STREET
&
COUNTRYSIDE COURT

HCM 6th TWSC
1: N Main Street & Countryside Court

2022 Existing
Timing Plan: AM Peak Hour

Intersection						
Int Delay, s/veh	0.5					
Movement	EBL	EBR	NBL	NBT	SBT	SBR
Lane Configurations	T			T		T
Traffic Vol, veh/h	6	15	6	200	448	7
Future Vol, veh/h	6	15	6	200	448	7
Conflicting Peds, #/hr	3	1	1	0	0	3
Sign Control	Stop	Stop	Free	Free	Free	Free
RT Channelized	-	None	-	None	-	None
Storage Length	0	-	-	-	-	-
Veh in Median Storage, #	0	-	-	0	0	-
Grade, %	0	-	-	0	0	-
Peak Hour Factor	78	78	78	78	78	78
Heavy Vehicles, %	0	7	17	2	1	0
Mvmt Flow	8	19	8	256	574	9

Major/Minor	Minor2	Major1	Major2			
Conflicting Flow All	857	583	586	0	-	0
Stage 1	582	-	-	-	-	-
Stage 2	275	-	-	-	-	-
Critical Hdwy	6.4	6.27	4.27	-	-	-
Critical Hdwy Stg 1	5.4	-	-	-	-	-
Critical Hdwy Stg 2	5.4	-	-	-	-	-
Follow-up Hdwy	3.5	3.363	2.353	-	-	-
Pot Cap-1 Maneuver	330	503	919	-	-	-
Stage 1	563	-	-	-	-	-
Stage 2	776	-	-	-	-	-
Platoon blocked, %				-	-	-
Mov Cap-1 Maneuver	325	501	916	-	-	-
Mov Cap-2 Maneuver	325	-	-	-	-	-
Stage 1	556	-	-	-	-	-
Stage 2	774	-	-	-	-	-

Approach	EB	NB	SB
HCM Control Delay, s	13.8	0.3	0
HCM LOS	B		

Minor Lane/Major Mvmt	NBL	NBT	EBLn1	SBT	SBR
Capacity (veh/h)	916	-	434	-	-
HCM Lane V/C Ratio	0.008	-	0.062	-	-
HCM Control Delay (s)	9	0	13.8	-	-
HCM Lane LOS	A	A	B	-	-
HCM 95th %tile Q(veh)	0	-	0.2	-	-

HCM 6th TWSC
1: N Main Street & Countryside Court

2022 Existing
Timing Plan: PM Peak Hour

Intersection						
Int Delay, s/veh	0.6					
Movement	EBL	EBR	NBL	NBT	SBT	SBR
Lane Configurations	T			T		T
Traffic Vol, veh/h	2	22	21	466	331	13
Future Vol, veh/h	2	22	21	466	331	13
Conflicting Peds, #/hr	1	1	1	0	0	1
Sign Control	Stop	Stop	Free	Free	Free	Free
RT Channelized	-	None	-	None	-	None
Storage Length	0	-	-	-	-	-
Veh in Median Storage, #	0	-	-	0	0	-
Grade, %	0	-	-	0	0	-
Peak Hour Factor	87	87	87	87	87	87
Heavy Vehicles, %	50	9	0	1	1	0
Mvmt Flow	2	25	24	536	380	15

Major/Minor	Minor2	Major1	Major2			
Conflicting Flow All	974	390	396	0	-	0
Stage 1	389	-	-	-	-	-
Stage 2	585	-	-	-	-	-
Critical Hdwy	6.9	6.29	4.1	-	-	-
Critical Hdwy Stg 1	5.9	-	-	-	-	-
Critical Hdwy Stg 2	5.9	-	-	-	-	-
Follow-up Hdwy	3.95	3.381	2.2	-	-	-
Pot Cap-1 Maneuver	229	643	1174	-	-	-
Stage 1	592	-	-	-	-	-
Stage 2	473	-	-	-	-	-
Platoon blocked, %				-	-	-
Mov Cap-1 Maneuver	222	642	1173	-	-	-
Mov Cap-2 Maneuver	222	-	-	-	-	-
Stage 1	574	-	-	-	-	-
Stage 2	473	-	-	-	-	-

Approach	EB	NB	SB
HCM Control Delay, s	11.8	0.4	0
HCM LOS	B		

Minor Lane/Major Mvmt	NBL	NBT	EBLn1	SBT	SBR
Capacity (veh/h)	1173	-	555	-	-
HCM Lane V/C Ratio	0.021	-	0.05	-	-
HCM Control Delay (s)	8.1	0	11.8	-	-
HCM Lane LOS	A	A	B	-	-
HCM 95th %tile Q(veh)	0.1	-	0.2	-	-

HCM 6th TWSC
 1: N Main Street & Countryside Court

2027 No-Build
 Timing Plan: AM Peak Hour

Intersection						
Int Delay, s/veh	0.5					
Movement	EBL	EBR	NBL	NBT	SBT	SBR
Lane Configurations	T			T		T
Traffic Vol, veh/h	7	17	7	231	517	8
Future Vol, veh/h	7	17	7	231	517	8
Conflicting Peds, #/hr	3	1	1	0	0	3
Sign Control	Stop	Stop	Free	Free	Free	Free
RT Channelized	-	None	-	None	-	None
Storage Length	0	-	-	-	-	-
Veh in Median Storage, #	0	-	-	0	0	-
Grade, %	0	-	-	0	0	-
Peak Hour Factor	92	92	92	92	92	92
Heavy Vehicles, %	0	7	17	2	1	0
Mvmt Flow	8	18	8	251	562	9

Major/Minor	Minor2	Major1	Major2			
Conflicting Flow All	840	571	574	0	-	0
Stage 1	570	-	-	-	-	-
Stage 2	270	-	-	-	-	-
Critical Hdwy	6.4	6.27	4.27	-	-	-
Critical Hdwy Stg 1	5.4	-	-	-	-	-
Critical Hdwy Stg 2	5.4	-	-	-	-	-
Follow-up Hdwy	3.5	3.363	2.353	-	-	-
Pot Cap-1 Maneuver	338	511	929	-	-	-
Stage 1	570	-	-	-	-	-
Stage 2	780	-	-	-	-	-
Platoon blocked, %				-	-	-
Mov Cap-1 Maneuver	333	509	926	-	-	-
Mov Cap-2 Maneuver	333	-	-	-	-	-
Stage 1	563	-	-	-	-	-
Stage 2	778	-	-	-	-	-

Approach	EB	NB	SB
HCM Control Delay, s	13.7	0.3	0
HCM LOS	B		

Minor Lane/Major Mvmt	NBL	NBT	EBLn1	SBT	SBR
Capacity (veh/h)	926	-	441	-	-
HCM Lane V/C Ratio	0.008	-	0.059	-	-
HCM Control Delay (s)	8.9	0	13.7	-	-
HCM Lane LOS	A	A	B	-	-
HCM 95th %tile Q(veh)	0	-	0.2	-	-

HCM 6th TWSC
 1: N Main Street & Countryside Court

2027 No-Build
 Timing Plan: PM Peak Hour

Intersection						
Int Delay, s/veh	0.6					
Movement	EBL	EBR	NBL	NBT	SBT	SBR
Lane Configurations	T			T		T
Traffic Vol, veh/h	2	25	24	535	382	15
Future Vol, veh/h	2	25	24	535	382	15
Conflicting Peds, #/hr	1	1	1	0	0	1
Sign Control	Stop	Stop	Free	Free	Free	Free
RT Channelized	-	None	-	None	-	None
Storage Length	0	-	-	-	-	-
Veh in Median Storage, #	0	-	-	0	0	-
Grade, %	0	-	-	0	0	-
Peak Hour Factor	92	92	92	92	92	92
Heavy Vehicles, %	50	9	0	1	1	0
Mvmt Flow	2	27	26	582	415	16

Major/Minor	Minor2	Major1	Major2			
Conflicting Flow All	1059	425	432	0	-	0
Stage 1	424	-	-	-	-	-
Stage 2	635	-	-	-	-	-
Critical Hdwy	6.9	6.29	4.1	-	-	-
Critical Hdwy Stg 1	5.9	-	-	-	-	-
Critical Hdwy Stg 2	5.9	-	-	-	-	-
Follow-up Hdwy	3.95	3.381	2.2	-	-	-
Pot Cap-1 Maneuver	202	615	1138	-	-	-
Stage 1	569	-	-	-	-	-
Stage 2	447	-	-	-	-	-
Platoon blocked, %				-	-	-
Mov Cap-1 Maneuver	195	614	1137	-	-	-
Mov Cap-2 Maneuver	195	-	-	-	-	-
Stage 1	549	-	-	-	-	-
Stage 2	447	-	-	-	-	-

Approach	EB	NB	SB
HCM Control Delay, s	12.2	0.4	0
HCM LOS	B		

Minor Lane/Major Mvmt	NBL	NBT	EBLn1	SBT	SBR
Capacity (veh/h)	1137	-	530	-	-
HCM Lane V/C Ratio	0.023	-	0.055	-	-
HCM Control Delay (s)	8.2	0	12.2	-	-
HCM Lane LOS	A	A	B	-	-
HCM 95th %tile Q(veh)	0.1	-	0.2	-	-

HCM 6th TWSC
 1: N Main Street & Countryside Court

2027 Build
 Timing Plan: AM Peak Hour

Intersection						
Int Delay, s/veh	0.6					
Movement	EBL	EBR	NBL	NBT	SBT	SBR
Lane Configurations	T			T		T
Traffic Vol, veh/h	9	23	9	233	518	9
Future Vol, veh/h	9	23	9	233	518	9
Conflicting Peds, #/hr	3	1	1	0	0	3
Sign Control	Stop	Stop	Free	Free	Free	Free
RT Channelized	-	None	-	None	-	None
Storage Length	0	-	-	-	-	-
Veh in Median Storage, #	0	-	-	0	0	-
Grade, %	0	-	-	0	0	-
Peak Hour Factor	92	92	92	92	92	92
Heavy Vehicles, %	0	7	17	2	1	0
Mvmt Flow	10	25	10	253	563	10

Major/Minor	Minor2	Major1	Major2			
Conflicting Flow All	847	572	576	0	-	0
Stage 1	571	-	-	-	-	-
Stage 2	276	-	-	-	-	-
Critical Hdwy	6.4	6.27	4.27	-	-	-
Critical Hdwy Stg 1	5.4	-	-	-	-	-
Critical Hdwy Stg 2	5.4	-	-	-	-	-
Follow-up Hdwy	3.5	3.363	2.353	-	-	-
Pot Cap-1 Maneuver	335	510	927	-	-	-
Stage 1	569	-	-	-	-	-
Stage 2	775	-	-	-	-	-
Platoon blocked, %				-	-	-
Mov Cap-1 Maneuver	329	508	924	-	-	-
Mov Cap-2 Maneuver	329	-	-	-	-	-
Stage 1	560	-	-	-	-	-
Stage 2	773	-	-	-	-	-

Approach	EB	NB	SB
HCM Control Delay, s	13.9	0.3	0
HCM LOS	B		

Minor Lane/Major Mvmt	NBL	NBT	EBLn1	SBT	SBR
Capacity (veh/h)	924	-	441	-	-
HCM Lane V/C Ratio	0.011	-	0.079	-	-
HCM Control Delay (s)	8.9	0	13.9	-	-
HCM Lane LOS	A	A	B	-	-
HCM 95th %tile Q(veh)	0	-	0.3	-	-

HCM 6th TWSC
 1: N Main Street & Countryside Court

2027 Build
 Timing Plan: PM Peak Hour

Intersection						
Int Delay, s/veh	0.7					
Movement	EBL	EBR	NBL	NBT	SBT	SBR
Lane Configurations	T			T		T
Traffic Vol, veh/h	3	29	31	536	384	17
Future Vol, veh/h	3	29	31	536	384	17
Conflicting Peds, #/hr	1	1	1	0	0	1
Sign Control	Stop	Stop	Free	Free	Free	Free
RT Channelized	-	None	-	None	-	None
Storage Length	0	-	-	-	-	-
Veh in Median Storage, #	0	-	-	0	0	-
Grade, %	0	-	-	0	0	-
Peak Hour Factor	92	92	92	92	92	92
Heavy Vehicles, %	50	9	0	1	1	0
Mvmt Flow	3	32	34	583	417	18

Major/Minor	Minor2	Major1	Major2			
Conflicting Flow All	1079	428	436	0	-	0
Stage 1	427	-	-	-	-	-
Stage 2	652	-	-	-	-	-
Critical Hdwy	6.9	6.29	4.1	-	-	-
Critical Hdwy Stg 1	5.9	-	-	-	-	-
Critical Hdwy Stg 2	5.9	-	-	-	-	-
Follow-up Hdwy	3.95	3.381	2.2	-	-	-
Pot Cap-1 Maneuver	197	612	1134	-	-	-
Stage 1	567	-	-	-	-	-
Stage 2	438	-	-	-	-	-
Platoon blocked, %				-	-	-
Mov Cap-1 Maneuver	188	611	1133	-	-	-
Mov Cap-2 Maneuver	188	-	-	-	-	-
Stage 1	541	-	-	-	-	-
Stage 2	438	-	-	-	-	-

Approach	EB	NB	SB
HCM Control Delay, s	12.7	0.5	0
HCM LOS	B		

Minor Lane/Major Mvmt	NBL	NBT	EBLn1	SBT	SBR
Capacity (veh/h)	1133	-	505	-	-
HCM Lane V/C Ratio	0.03	-	0.069	-	-
HCM Control Delay (s)	8.3	0	12.7	-	-
HCM Lane LOS	A	A	B	-	-
HCM 95th %tile Q(veh)	0.1	-	0.2	-	-

CAPACITY ANALYSIS CALCULATIONS
N MAIN STREET
&
GIVENS LANE

HCM 6th TWSC
2: N Main Street & Givens Lane/Mountain Breeze Drive

2022 Existing
Timing Plan: AM Peak Hour

Intersection												
Int Delay, s/veh	1.4											
Movement	EBL	EBT	EBR	WBL	WBT	WBR	NBL	NBT	NBR	SBL	SBT	SBR
Lane Configurations		↕			↕			↕			↕	
Traffic Vol, veh/h	15	0	8	13	8	7	12	184	5	7	415	41
Future Vol, veh/h	15	0	8	13	8	7	12	184	5	7	415	41
Conflicting Peds, #/hr	7	0	5	15	0	17	5	0	15	17	0	7
Sign Control	Stop	Stop	Stop	Stop	Stop	Stop	Free	Free	Free	Free	Free	Free
RT Channelized	-	-	None	-	-	None	-	-	None	-	-	None
Storage Length	-	-	-	-	-	-	-	-	-	-	-	-
Veh in Median Storage, #	-	0	-	-	0	-	-	0	-	-	0	-
Grade, %	-	0	-	-	0	-	-	0	-	-	0	-
Peak Hour Factor	85	85	85	85	85	85	85	85	85	85	85	85
Heavy Vehicles, %	2	13	6	1	1	7	35	2	0	1	2	5
Mvmt Flow	18	0	9	15	9	8	14	216	6	8	488	48

Major/Minor	Minor2		Minor1		Major1		Major2					
Conflicting Flow All	808	802	534	812	823	253	543	0	0	239	0	0
Stage 1	535	535	-	264	264	-	-	-	-	-	-	-
Stage 2	273	267	-	548	559	-	-	-	-	-	-	-
Critical Hdwy	7.12	6.63	6.26	7.11	6.51	6.27	4.45	-	-	4.11	-	-
Critical Hdwy Stg 1	6.12	5.63	-	6.11	5.51	-	-	-	-	-	-	-
Critical Hdwy Stg 2	6.12	5.63	-	6.11	5.51	-	-	-	-	-	-	-
Follow-up Hdwy	3.518	4.117	3.354	3.509	4.009	3.363	2.515	-	-	2.209	-	-
Pot Cap-1 Maneuver	299	305	538	299	310	774	879	-	-	1334	-	-
Stage 1	529	506	-	743	692	-	-	-	-	-	-	-
Stage 2	733	668	-	522	513	-	-	-	-	-	-	-
Platoon blocked, %								-	-	-	-	-
Mov Cap-1 Maneuver	276	290	527	279	295	749	873	-	-	1312	-	-
Mov Cap-2 Maneuver	276	290	-	279	295	-	-	-	-	-	-	-
Stage 1	516	498	-	718	668	-	-	-	-	-	-	-
Stage 2	690	645	-	501	505	-	-	-	-	-	-	-

Approach	EB		WB		NB		SB	
HCM Control Delay, s	16.8		16.8		0.5		0.1	
HCM LOS	C		C					

Minor Lane/Major Mvmt	NBL	NBT	NBR	EBLn1WBLn1	SBL	SBT	SBR
Capacity (veh/h)	873	-	-	331	337	1312	-
HCM Lane V/C Ratio	0.016	-	-	0.082	0.098	0.006	-
HCM Control Delay (s)	9.2	0	-	16.8	16.8	7.8	0
HCM Lane LOS	A	A	-	C	C	A	A
HCM 95th %tile Q(veh)	0	-	-	0.3	0.3	0	-

HCM 6th TWSC
2: N Main Street & Givens Lane/Mountain Breeze Drive

2022 Existing
Timing Plan: PM Peak Hour

Intersection												
Int Delay, s/veh	1.7											
Movement	EBL	EBT	EBR	WBL	WBT	WBR	NBL	NBT	NBR	SBL	SBT	SBR
Lane Configurations		↕			↕			↕			↕	
Traffic Vol, veh/h	16	4	16	20	6	7	23	464	22	12	302	39
Future Vol, veh/h	16	4	16	20	6	7	23	464	22	12	302	39
Conflicting Peds, #/hr	6	0	0	0	0	6	0	0	0	6	0	6
Sign Control	Stop	Stop	Stop	Stop	Stop	Stop	Free	Free	Free	Free	Free	Free
RT Channelized	-	-	None	-	-	None	-	-	None	-	-	None
Storage Length	-	-	-	-	-	-	-	-	-	-	-	-
Veh in Median Storage, #	-	0	-	-	0	-	-	0	-	-	0	-
Grade, %	-	0	-	-	0	-	-	0	-	-	0	-
Peak Hour Factor	97	97	97	97	97	97	97	97	97	97	97	97
Heavy Vehicles, %	2	13	6	1	1	7	35	2	0	1	2	5
Mvmt Flow	16	4	16	21	6	7	24	478	23	12	311	40

Major/Minor	Minor2		Minor1		Major1			Major2				
Conflicting Flow All	911	916	337	909	925	502	357	0	0	507	0	0
Stage 1	361	361	-	544	544	-	-	-	-	-	-	-
Stage 2	550	555	-	365	381	-	-	-	-	-	-	-
Critical Hdwy	7.12	6.63	6.26	7.11	6.51	6.27	4.45	-	-	4.11	-	-
Critical Hdwy Stg 1	6.12	5.63	-	6.11	5.51	-	-	-	-	-	-	-
Critical Hdwy Stg 2	6.12	5.63	-	6.11	5.51	-	-	-	-	-	-	-
Follow-up Hdwy	3.518	4.117	3.354	3.509	4.009	3.363	2.515	-	-	2.209	-	-
Pot Cap-1 Maneuver	255	261	696	257	270	559	1040	-	-	1063	-	-
Stage 1	657	607	-	525	521	-	-	-	-	-	-	-
Stage 2	519	496	-	656	615	-	-	-	-	-	-	-
Platoon blocked, %								-	-	-	-	-
Mov Cap-1 Maneuver	236	246	692	238	255	553	1034	-	-	1057	-	-
Mov Cap-2 Maneuver	236	246	-	238	255	-	-	-	-	-	-	-
Stage 1	632	595	-	505	501	-	-	-	-	-	-	-
Stage 2	487	477	-	627	603	-	-	-	-	-	-	-

Approach	EB		WB		NB		SB	
HCM Control Delay, s	17		20		0.4		0.3	
HCM LOS	C		C					

Minor Lane/Major Mvmt	NBL	NBT	NBR	EBLn1WBLn1	SBL	SBT	SBR
Capacity (veh/h)	1034	-	-	336	274	1057	-
HCM Lane V/C Ratio	0.023	-	-	0.11	0.124	0.012	-
HCM Control Delay (s)	8.6	0	-	17	20	8.4	0
HCM Lane LOS	A	A	-	C	C	A	A
HCM 95th %tile Q(veh)	0.1	-	-	0.4	0.4	0	-

Intersection												
Int Delay, s/veh	1.7											
Movement	EBL	EBT	EBR	WBL	WBT	WBR	NBL	NBT	NBR	SBL	SBT	SBR
Lane Configurations		↕			↕			↕			↕	
Traffic Vol, veh/h	19	1	9	15	12	9	14	210	6	8	477	49
Future Vol, veh/h	19	1	9	15	12	9	14	210	6	8	477	49
Conflicting Peds, #/hr	7	0	5	15	0	17	5	0	15	17	0	7
Sign Control	Stop	Stop	Stop	Stop	Stop	Stop	Free	Free	Free	Free	Free	Free
RT Channelized	-	-	None	-	-	None	-	-	None	-	-	None
Storage Length	-	-	-	-	-	-	-	-	-	-	-	-
Veh in Median Storage, #	-	0	-	-	0	-	-	0	-	-	0	-
Grade, %	-	0	-	-	0	-	-	0	-	-	0	-
Peak Hour Factor	92	92	92	92	92	92	92	92	92	92	92	92
Heavy Vehicles, %	2	13	6	1	1	7	35	2	0	1	2	5
Mvmt Flow	21	1	10	16	13	10	15	228	7	9	518	53

Major/Minor	Minor2		Minor1		Major1		Major2					
Conflicting Flow All	860	852	567	862	875	266	578	0	0	252	0	0
Stage 1	570	570	-	279	279	-	-	-	-	-	-	-
Stage 2	290	282	-	583	596	-	-	-	-	-	-	-
Critical Hdwy	7.12	6.63	6.26	7.11	6.51	6.27	4.45	-	-	4.11	-	-
Critical Hdwy Stg 1	6.12	5.63	-	6.11	5.51	-	-	-	-	-	-	-
Critical Hdwy Stg 2	6.12	5.63	-	6.11	5.51	-	-	-	-	-	-	-
Follow-up Hdwy	3.518	4.117	3.354	3.509	4.009	3.363	2.515	-	-	2.209	-	-
Pot Cap-1 Maneuver	276	285	515	276	289	761	852	-	-	1319	-	-
Stage 1	506	488	-	730	682	-	-	-	-	-	-	-
Stage 2	718	658	-	500	493	-	-	-	-	-	-	-
Platoon blocked, %								-	-	-	-	-
Mov Cap-1 Maneuver	251	270	504	256	274	737	846	-	-	1298	-	-
Mov Cap-2 Maneuver	251	270	-	256	274	-	-	-	-	-	-	-
Stage 1	492	480	-	704	657	-	-	-	-	-	-	-
Stage 2	669	634	-	477	485	-	-	-	-	-	-	-

Approach	EB		WB		NB		SB	
HCM Control Delay, s	18.5		18.1		0.6		0.1	
HCM LOS	C		C					

Minor Lane/Major Mvmt	NBL	NBT	NBR	EBLn1WBLn1	SBL	SBT	SBR
Capacity (veh/h)	846	-	-	298	314	1298	-
HCM Lane V/C Ratio	0.018	-	-	0.106	0.125	0.007	-
HCM Control Delay (s)	9.3	0	-	18.5	18.1	7.8	0
HCM Lane LOS	A	A	-	C	C	A	A
HCM 95th %tile Q(veh)	0.1	-	-	0.4	0.4	0	-

HCM 6th TWSC
 2: N Main Street & Givens Lane/Mountain Breeze Drive

2027 No-Build
 Timing Plan: PM Peak Hour

Intersection												
Int Delay, s/veh	2.2											
Movement	EBL	EBT	EBR	WBL	WBT	WBR	NBL	NBT	NBR	SBL	SBT	SBR
Lane Configurations		↕			↕			↕			↕	
Traffic Vol, veh/h	22	7	18	23	9	9	26	528	25	15	345	48
Future Vol, veh/h	22	7	18	23	9	9	26	528	25	15	345	48
Conflicting Peds, #/hr	6	0	0	0	0	6	0	0	0	6	0	6
Sign Control	Stop	Stop	Stop	Stop	Stop	Stop	Free	Free	Free	Free	Free	Free
RT Channelized	-	-	None	-	-	None	-	-	None	-	-	None
Storage Length	-	-	-	-	-	-	-	-	-	-	-	-
Veh in Median Storage, #	-	0	-	-	0	-	-	0	-	-	0	-
Grade, %	-	0	-	-	0	-	-	0	-	-	0	-
Peak Hour Factor	97	97	97	97	97	97	97	97	97	97	97	97
Heavy Vehicles, %	2	13	6	1	1	7	35	2	0	1	2	5
Mvmt Flow	23	7	19	24	9	9	27	544	26	15	356	49

Major/Minor	Minor2		Minor1		Major1		Major2					
Conflicting Flow All	1043	1047	387	1041	1058	569	411	0	0	576	0	0
Stage 1	417	417	-	617	617	-	-	-	-	-	-	-
Stage 2	626	630	-	424	441	-	-	-	-	-	-	-
Critical Hdwy	7.12	6.63	6.26	7.11	6.51	6.27	4.45	-	-	4.11	-	-
Critical Hdwy Stg 1	6.12	5.63	-	6.11	5.51	-	-	-	-	-	-	-
Critical Hdwy Stg 2	6.12	5.63	-	6.11	5.51	-	-	-	-	-	-	-
Follow-up Hdwy	3.518	4.117	3.354	3.509	4.009	3.363	2.515	-	-	2.209	-	-
Pot Cap-1 Maneuver	207	218	652	209	226	512	991	-	-	1002	-	-
Stage 1	613	573	-	479	483	-	-	-	-	-	-	-
Stage 2	472	458	-	610	579	-	-	-	-	-	-	-
Platoon blocked, %								-	-	-	-	-
Mov Cap-1 Maneuver	185	203	648	187	210	506	985	-	-	996	-	-
Mov Cap-2 Maneuver	185	203	-	187	210	-	-	-	-	-	-	-
Stage 1	585	558	-	457	461	-	-	-	-	-	-	-
Stage 2	433	437	-	573	564	-	-	-	-	-	-	-

Approach	EB		WB		NB		SB	
HCM Control Delay, s	22.1		24.9		0.4		0.3	
HCM LOS	C		C					

Minor Lane/Major Mvmt	NBL	NBT	NBR	EBLn1WBLn1	SBL	SBT	SBR
Capacity (veh/h)	985	-	-	259	223	996	-
HCM Lane V/C Ratio	0.027	-	-	0.187	0.19	0.016	-
HCM Control Delay (s)	8.8	0	-	22.1	24.9	8.7	0
HCM Lane LOS	A	A	-	C	C	A	A
HCM 95th %tile Q(veh)	0.1	-	-	0.7	0.7	0	-

HCM 6th TWSC
 2: N Main Street & Givens Lane/Mountain Breeze Drive

2027 Build
 Timing Plan: AM Peak Hour

Intersection												
Int Delay, s/veh	1.9											
Movement	EBL	EBT	EBR	WBL	WBT	WBR	NBL	NBT	NBR	SBL	SBT	SBR
Lane Configurations		↕			↕			↕			↕	
Traffic Vol, veh/h	21	1	19	15	12	9	16	212	6	8	483	50
Future Vol, veh/h	21	1	19	15	12	9	16	212	6	8	483	50
Conflicting Peds, #/hr	7	0	5	15	0	17	5	0	15	17	0	7
Sign Control	Stop	Stop	Stop	Stop	Stop	Stop	Free	Free	Free	Free	Free	Free
RT Channelized	-	-	None	-	-	None	-	-	None	-	-	None
Storage Length	-	-	-	-	-	-	-	-	-	-	-	-
Veh in Median Storage, #	-	0	-	-	0	-	-	0	-	-	0	-
Grade, %	-	0	-	-	0	-	-	0	-	-	0	-
Peak Hour Factor	92	92	92	92	92	92	92	92	92	92	92	92
Heavy Vehicles, %	2	13	6	1	1	7	35	2	0	1	2	5
Mvmt Flow	23	1	21	16	13	10	17	230	7	9	525	54

Major/Minor	Minor2		Minor1		Major1		Major2					
Conflicting Flow All	873	865	574	881	889	268	586	0	0	254	0	0
Stage 1	577	577	-	285	285	-	-	-	-	-	-	-
Stage 2	296	288	-	596	604	-	-	-	-	-	-	-
Critical Hdwy	7.12	6.63	6.26	7.11	6.51	6.27	4.45	-	-	4.11	-	-
Critical Hdwy Stg 1	6.12	5.63	-	6.11	5.51	-	-	-	-	-	-	-
Critical Hdwy Stg 2	6.12	5.63	-	6.11	5.51	-	-	-	-	-	-	-
Follow-up Hdwy	3.518	4.117	3.354	3.509	4.009	3.363	2.515	-	-	2.209	-	-
Pot Cap-1 Maneuver	271	280	511	268	283	759	845	-	-	1317	-	-
Stage 1	502	484	-	724	678	-	-	-	-	-	-	-
Stage 2	712	654	-	492	489	-	-	-	-	-	-	-
Platoon blocked, %								-	-	-	-	-
Mov Cap-1 Maneuver	245	265	500	242	267	735	839	-	-	1296	-	-
Mov Cap-2 Maneuver	245	265	-	242	267	-	-	-	-	-	-	-
Stage 1	487	476	-	696	652	-	-	-	-	-	-	-
Stage 2	662	628	-	459	481	-	-	-	-	-	-	-

Approach	EB		WB		NB		SB			
HCM Control Delay, s	18		18.7		0.6		0.1			
HCM LOS	C		C							

Minor Lane/Major Mvmt	NBL	NBT	NBR	EBLn1WBLn1	SBL	SBT	SBR
Capacity (veh/h)	839	-	-	322	302	1296	-
HCM Lane V/C Ratio	0.021	-	-	0.138	0.13	0.007	-
HCM Control Delay (s)	9.4	0	-	18	18.7	7.8	0
HCM Lane LOS	A	A	-	C	C	A	A
HCM 95th %tile Q(veh)	0.1	-	-	0.5	0.4	0	-

HCM 6th TWSC
 2: N Main Street & Givens Lane/Mountain Breeze Drive

2027 Build
 Timing Plan: PM Peak Hour

Intersection												
Int Delay, s/veh	2.6											
Movement	EBL	EBT	EBR	WBL	WBT	WBR	NBL	NBT	NBR	SBL	SBT	SBR
Lane Configurations		↕			↕			↕			↕	
Traffic Vol, veh/h	23	7	26	23	9	9	38	535	25	15	349	50
Future Vol, veh/h	23	7	26	23	9	9	38	535	25	15	349	50
Conflicting Peds, #/hr	6	0	0	0	0	6	0	0	0	6	0	6
Sign Control	Stop	Stop	Stop	Stop	Stop	Stop	Free	Free	Free	Free	Free	Free
RT Channelized	-	-	None	-	-	None	-	-	None	-	-	None
Storage Length	-	-	-	-	-	-	-	-	-	-	-	-
Veh in Median Storage, #	-	0	-	-	0	-	-	0	-	-	0	-
Grade, %	-	0	-	-	0	-	-	0	-	-	0	-
Peak Hour Factor	97	97	97	97	97	97	97	97	97	97	97	97
Heavy Vehicles, %	2	13	6	1	1	7	35	2	0	1	2	5
Mvmt Flow	24	7	27	24	9	9	39	552	26	15	360	52

Major/Minor	Minor2		Minor1		Major1			Major2				
Conflicting Flow All	1080	1084	392	1082	1097	577	418	0	0	584	0	0
Stage 1	422	422	-	649	649	-	-	-	-	-	-	-
Stage 2	658	662	-	433	448	-	-	-	-	-	-	-
Critical Hdwy	7.12	6.63	6.26	7.11	6.51	6.27	4.45	-	-	4.11	-	-
Critical Hdwy Stg 1	6.12	5.63	-	6.11	5.51	-	-	-	-	-	-	-
Critical Hdwy Stg 2	6.12	5.63	-	6.11	5.51	-	-	-	-	-	-	-
Follow-up Hdwy	3.518	4.117	3.354	3.509	4.009	3.363	2.515	-	-	2.209	-	-
Pot Cap-1 Maneuver	196	207	648	196	214	507	985	-	-	996	-	-
Stage 1	609	570	-	460	467	-	-	-	-	-	-	-
Stage 2	453	443	-	603	575	-	-	-	-	-	-	-
Platoon blocked, %								-	-	-	-	-
Mov Cap-1 Maneuver	172	189	644	171	195	501	979	-	-	990	-	-
Mov Cap-2 Maneuver	172	189	-	171	195	-	-	-	-	-	-	-
Stage 1	570	555	-	431	437	-	-	-	-	-	-	-
Stage 2	407	414	-	559	560	-	-	-	-	-	-	-

Approach	EB		WB		NB		SB	
HCM Control Delay, s	22.3		26.9		0.6		0.3	
HCM LOS	C		D					

Minor Lane/Major Mvmt	NBL	NBT	NBR	EBLn1WBLn1	SBL	SBT	SBR
Capacity (veh/h)	979	-	-	265	206	990	-
HCM Lane V/C Ratio	0.04	-	-	0.218	0.205	0.016	-
HCM Control Delay (s)	8.8	0	-	22.3	26.9	8.7	0
HCM Lane LOS	A	A	-	C	D	A	A
HCM 95th %tile Q(veh)	0.1	-	-	0.8	0.7	0	-

CAPACITY ANALYSIS CALCULATIONS
GIVENS LANE
&
CARROLL DRIVE

Intersection						
Int Delay, s/veh	3.4					
Movement	EBL	EBT	WBT	WBR	SBL	SBR
Lane Configurations		↕	↕		↕	
Traffic Vol, veh/h	17	33	87	3	11	45
Future Vol, veh/h	17	33	87	3	11	45
Conflicting Peds, #/hr	0	0	0	0	0	0
Sign Control	Free	Free	Free	Free	Stop	Stop
RT Channelized	-	None	-	None	-	None
Storage Length	-	-	-	-	0	-
Veh in Median Storage, #	-	0	0	-	0	-
Grade, %	-	0	0	-	0	-
Peak Hour Factor	71	71	71	71	71	71
Heavy Vehicles, %	6	9	3	0	9	2
Mvmt Flow	24	46	123	4	15	63

Major/Minor	Major1	Major2	Minor2		
Conflicting Flow All	127	0	-	0	219
Stage 1	-	-	-	-	125
Stage 2	-	-	-	-	94
Critical Hdwy	4.16	-	-	-	6.49
Critical Hdwy Stg 1	-	-	-	-	5.49
Critical Hdwy Stg 2	-	-	-	-	5.49
Follow-up Hdwy	2.254	-	-	-	3.581
Pot Cap-1 Maneuver	1435	-	-	-	754
Stage 1	-	-	-	-	884
Stage 2	-	-	-	-	912
Platoon blocked, %		-	-	-	
Mov Cap-1 Maneuver	1435	-	-	-	741
Mov Cap-2 Maneuver	-	-	-	-	741
Stage 1	-	-	-	-	869
Stage 2	-	-	-	-	912

Approach	EB	WB	SB
HCM Control Delay, s	2.6	0	9.5
HCM LOS			A

Minor Lane/Major Mvmt	EBL	EBT	WBT	WBR	SBLn1
Capacity (veh/h)	1435	-	-	-	883
HCM Lane V/C Ratio	0.017	-	-	-	0.089
HCM Control Delay (s)	7.6	0	-	-	9.5
HCM Lane LOS	A	A	-	-	A
HCM 95th %tile Q(veh)	0.1	-	-	-	0.3

Intersection						
Int Delay, s/veh	2.6					
Movement	EBL	EBT	WBT	WBR	SBL	SBR
Lane Configurations		↕	↕		↕	
Traffic Vol, veh/h	37	55	88	17	12	22
Future Vol, veh/h	37	55	88	17	12	22
Conflicting Peds, #/hr	4	0	0	2	2	4
Sign Control	Free	Free	Free	Free	Stop	Stop
RT Channelized	-	None	-	None	-	None
Storage Length	-	-	-	-	0	-
Veh in Median Storage, #	-	0	0	-	0	-
Grade, %	-	0	0	-	0	-
Peak Hour Factor	88	88	88	88	88	88
Heavy Vehicles, %	3	7	6	0	0	5
Mvmt Flow	42	63	100	19	14	25

Major/Minor	Major1	Major2	Minor2		
Conflicting Flow All	123	0	-	0	263
Stage 1	-	-	-	-	114
Stage 2	-	-	-	-	149
Critical Hdwy	4.13	-	-	-	6.4
Critical Hdwy Stg 1	-	-	-	-	5.4
Critical Hdwy Stg 2	-	-	-	-	5.4
Follow-up Hdwy	2.227	-	-	-	3.5
Pot Cap-1 Maneuver	1458	-	-	-	730
Stage 1	-	-	-	-	916
Stage 2	-	-	-	-	884
Platoon blocked, %		-	-	-	
Mov Cap-1 Maneuver	1452	-	-	-	702
Mov Cap-2 Maneuver	-	-	-	-	702
Stage 1	-	-	-	-	885
Stage 2	-	-	-	-	880

Approach	EB	WB	SB
HCM Control Delay, s	3	0	9.6
HCM LOS			A

Minor Lane/Major Mvmt	EBL	EBT	WBT	WBR	SBLn1
Capacity (veh/h)	1452	-	-	-	829
HCM Lane V/C Ratio	0.029	-	-	-	0.047
HCM Control Delay (s)	7.6	0	-	-	9.6
HCM Lane LOS	A	A	-	-	A
HCM 95th %tile Q(veh)	0.1	-	-	-	0.1

Intersection						
Int Delay, s/veh	3.1					
Movement	EBL	EBT	WBT	WBR	SBL	SBR
Lane Configurations		↶	↷		↶	↷
Traffic Vol, veh/h	19	41	108	3	12	51
Future Vol, veh/h	19	41	108	3	12	51
Conflicting Peds, #/hr	0	0	0	0	0	0
Sign Control	Free	Free	Free	Free	Stop	Stop
RT Channelized	-	None	-	None	-	None
Storage Length	-	-	-	-	0	-
Veh in Median Storage, #	-	0	0	-	0	-
Grade, %	-	0	0	-	0	-
Peak Hour Factor	92	92	92	92	92	92
Heavy Vehicles, %	6	9	3	0	9	2
Mvmt Flow	21	45	117	3	13	55

Major/Minor	Major1	Major2	Minor2		
Conflicting Flow All	120	0	0	206	119
Stage 1	-	-	-	119	-
Stage 2	-	-	-	87	-
Critical Hdwy	4.16	-	-	6.49	6.22
Critical Hdwy Stg 1	-	-	-	5.49	-
Critical Hdwy Stg 2	-	-	-	5.49	-
Follow-up Hdwy	2.254	-	-	3.581	3.318
Pot Cap-1 Maneuver	1443	-	-	767	933
Stage 1	-	-	-	889	-
Stage 2	-	-	-	919	-
Platoon blocked, %	-	-	-	-	-
Mov Cap-1 Maneuver	1443	-	-	755	933
Mov Cap-2 Maneuver	-	-	-	755	-
Stage 1	-	-	-	876	-
Stage 2	-	-	-	919	-

Approach	EB	WB	SB
HCM Control Delay, s	2.4	0	9.4
HCM LOS			A

Minor Lane/Major Mvmt	EBL	EBT	WBT	WBR	SBLn1
Capacity (veh/h)	1443	-	-	-	893
HCM Lane V/C Ratio	0.014	-	-	-	0.077
HCM Control Delay (s)	7.5	0	-	-	9.4
HCM Lane LOS	A	A	-	-	A
HCM 95th %tile Q(veh)	0	-	-	-	0.2

Intersection						
Int Delay, s/veh	2.5					
Movement	EBL	EBT	WBT	WBR	SBL	SBR
Lane Configurations		↶	↷		↶	↷
Traffic Vol, veh/h	42	70	108	19	14	25
Future Vol, veh/h	42	70	108	19	14	25
Conflicting Peds, #/hr	4	0	0	2	2	4
Sign Control	Free	Free	Free	Free	Stop	Stop
RT Channelized	-	None	-	None	-	None
Storage Length	-	-	-	-	0	-
Veh in Median Storage, #	-	0	0	-	0	-
Grade, %	-	0	0	-	0	-
Peak Hour Factor	92	92	92	92	92	92
Heavy Vehicles, %	3	7	6	0	0	5
Mvmt Flow	46	76	117	21	15	27

Major/Minor	Major1	Major2	Minor2		
Conflicting Flow All	142	0	-	0	302
Stage 1	-	-	-	-	132
Stage 2	-	-	-	-	170
Critical Hdwy	4.13	-	-	-	6.4
Critical Hdwy Stg 1	-	-	-	-	5.4
Critical Hdwy Stg 2	-	-	-	-	5.4
Follow-up Hdwy	2.227	-	-	-	3.5
Pot Cap-1 Maneuver	1435	-	-	-	694
Stage 1	-	-	-	-	899
Stage 2	-	-	-	-	865
Platoon blocked, %		-	-	-	
Mov Cap-1 Maneuver	1430	-	-	-	665
Mov Cap-2 Maneuver	-	-	-	-	665
Stage 1	-	-	-	-	865
Stage 2	-	-	-	-	862

Approach	EB	WB	SB
HCM Control Delay, s	2.9	0	9.8
HCM LOS			A

Minor Lane/Major Mvmt	EBL	EBT	WBT	WBR	SBLn1
Capacity (veh/h)	1430	-	-	-	798
HCM Lane V/C Ratio	0.032	-	-	-	0.053
HCM Control Delay (s)	7.6	0	-	-	9.8
HCM Lane LOS	A	A	-	-	A
HCM 95th %tile Q(veh)	0.1	-	-	-	0.2

Intersection						
Int Delay, s/veh	3.5					
Movement	EBL	EBT	WBT	WBR	SBL	SBR
Lane Configurations		↕	↕		↕	
Traffic Vol, veh/h	20	43	109	5	22	53
Future Vol, veh/h	20	43	109	5	22	53
Conflicting Peds, #/hr	0	0	0	0	0	0
Sign Control	Free	Free	Free	Free	Stop	Stop
RT Channelized	-	None	-	None	-	None
Storage Length	-	-	-	-	0	-
Veh in Median Storage, #	-	0	0	-	0	-
Grade, %	-	0	0	-	0	-
Peak Hour Factor	92	92	92	92	92	92
Heavy Vehicles, %	6	9	3	0	9	2
Mvmt Flow	22	47	118	5	24	58

Major/Minor	Major1	Major2	Minor2		
Conflicting Flow All	123	0	-	0	212
Stage 1	-	-	-	-	121
Stage 2	-	-	-	-	91
Critical Hdwy	4.16	-	-	-	6.49
Critical Hdwy Stg 1	-	-	-	-	5.49
Critical Hdwy Stg 2	-	-	-	-	5.49
Follow-up Hdwy	2.254	-	-	-	3.581
Pot Cap-1 Maneuver	1440	-	-	-	761
Stage 1	-	-	-	-	887
Stage 2	-	-	-	-	915
Platoon blocked, %		-	-	-	
Mov Cap-1 Maneuver	1440	-	-	-	749
Mov Cap-2 Maneuver	-	-	-	-	749
Stage 1	-	-	-	-	873
Stage 2	-	-	-	-	915

Approach	EB	WB	SB
HCM Control Delay, s	2.4	0	9.6
HCM LOS			A

Minor Lane/Major Mvmt	EBL	EBT	WBT	WBR	SBLn1
Capacity (veh/h)	1440	-	-	-	868
HCM Lane V/C Ratio	0.015	-	-	-	0.094
HCM Control Delay (s)	7.5	0	-	-	9.6
HCM Lane LOS	A	A	-	-	A
HCM 95th %tile Q(veh)	0	-	-	-	0.3

Intersection						
Int Delay, s/veh	2.7					
Movement	EBL	EBT	WBT	WBR	SBL	SBR
Lane Configurations		↶	↷		↶	↷
Traffic Vol, veh/h	44	71	110	31	22	26
Future Vol, veh/h	44	71	110	31	22	26
Conflicting Peds, #/hr	4	0	0	2	2	4
Sign Control	Free	Free	Free	Free	Stop	Stop
RT Channelized	-	None	-	None	-	None
Storage Length	-	-	-	-	0	-
Veh in Median Storage, #	-	0	0	-	0	-
Grade, %	-	0	0	-	0	-
Peak Hour Factor	92	92	92	92	92	92
Heavy Vehicles, %	3	7	6	0	0	5
Mvmt Flow	48	77	120	34	24	28

Major/Minor	Major1	Major2	Minor2		
Conflicting Flow All	158	0	-	0	316
Stage 1	-	-	-	-	141
Stage 2	-	-	-	-	175
Critical Hdwy	4.13	-	-	-	6.4
Critical Hdwy Stg 1	-	-	-	-	5.4
Critical Hdwy Stg 2	-	-	-	-	5.4
Follow-up Hdwy	2.227	-	-	-	3.5
Pot Cap-1 Maneuver	1416	-	-	-	681
Stage 1	-	-	-	-	891
Stage 2	-	-	-	-	860
Platoon blocked, %		-	-	-	
Mov Cap-1 Maneuver	1411	-	-	-	651
Mov Cap-2 Maneuver	-	-	-	-	651
Stage 1	-	-	-	-	855
Stage 2	-	-	-	-	857

Approach	EB	WB	SB
HCM Control Delay, s	2.9	0	10.1
HCM LOS			B

Minor Lane/Major Mvmt	EBL	EBT	WBT	WBR	SBLn1
Capacity (veh/h)	1411	-	-	-	761
HCM Lane V/C Ratio	0.034	-	-	-	0.069
HCM Control Delay (s)	7.6	0	-	-	10.1
HCM Lane LOS	A	A	-	-	B
HCM 95th %tile Q(veh)	0.1	-	-	-	0.2

**CAPACITY ANALYSIS CALCULATIONS
PROGRESS STREET
&
GIVENS LANE**

MOVEMENT SUMMARY

 Site: 101 [2022 Existing AM Peak Hour (Site Folder: General)]

Givens Lane and Progress Street

Site Category: Existing Design
Roundabout

Vehicle Movement Performance														
Mov ID	Turn	INPUT VOLUMES		DEMAND FLOWS		Deg. Satn v/c	Aver. Delay sec	Level of Service	95% BACK OF QUEUE		Prop. Que	Effective Stop Rate	Aver. No. Cycles	Aver. Speed mph
		[Total veh/h	HV] %	[Total veh/h	HV] %				[Veh. veh	Dist] ft				
South: Progress Street														
3	L2	3	33.0	3	33.0	0.020	3.8	LOS A	0.1	2.1	0.13	0.04	0.13	25.2
3	T1	3	67.0	3	67.0	0.020	4.7	LOS A	0.1	2.1	0.13	0.04	0.13	24.7
14	R2	14	0.0	16	0.0	0.020	2.9	LOS A	0.1	2.1	0.13	0.04	0.13	24.1
Approach		20	15.0	23	15.0	0.020	3.3	LOS A	0.1	2.1	0.13	0.04	0.13	24.3
East: Givens Lane														
14	L2	14	0.0	16	0.0	0.126	3.7	LOS A	0.6	15.0	0.09	0.02	0.09	25.4
133	T1	133	0.0	153	0.0	0.126	3.7	LOS A	0.6	15.0	0.09	0.02	0.09	24.8
0	R2	1	0.0	1	0.0	0.126	3.7	LOS A	0.6	15.0	0.09	0.02	0.09	24.2
Approach		148	0.0	170	0.0	0.126	3.7	LOS A	0.6	15.0	0.09	0.02	0.09	24.9
North: Progress Street														
1u	U	1	0.0	1	0.0	0.034	3.4	LOS A	0.1	3.4	0.30	0.16	0.30	25.8
0	L2	1	0.0	1	0.0	0.034	3.4	LOS A	0.1	3.4	0.30	0.16	0.30	25.1
11	T1	11	45.0	13	45.0	0.034	4.8	LOS A	0.1	3.4	0.30	0.16	0.30	24.6
16	R2	16	0.0	18	0.0	0.034	3.4	LOS A	0.1	3.4	0.30	0.16	0.30	24.0
Approach		29	17.1	33	17.1	0.034	3.9	LOS A	0.1	3.4	0.30	0.16	0.30	24.3
West: Givens Lane														
6	L2	6	0.0	7	0.0	0.033	3.0	LOS A	0.1	3.5	0.13	0.04	0.13	25.4
28	T1	28	0.0	32	0.0	0.033	3.0	LOS A	0.1	3.5	0.13	0.04	0.13	24.9
3	R2	3	33.0	3	33.0	0.033	3.9	LOS A	0.1	3.5	0.13	0.04	0.13	24.3
Approach		37	2.7	43	2.7	0.033	3.0	LOS A	0.1	3.5	0.13	0.04	0.13	24.9
All Vehicles		234	3.8	269	3.8	0.126	3.6	LOS A	0.6	15.0	0.13	0.04	0.13	24.8

Site Level of Service (LOS) Method: Delay & v/c (HCM 6). Site LOS Method is specified in the Parameter Settings dialog (Site tab).

Roundabout LOS Method: Same as Sign Control.

Vehicle movement LOS values are based on average delay and v/c ratio (degree of saturation) per movement.

LOS F will result if v/c > 1 irrespective of movement delay value (does not apply for approaches and intersection).

Intersection and Approach LOS values are based on average delay for all movements (v/c not used as specified in HCM 6).

Roundabout Capacity Model: US HCM 6.

Delay Model: HCM Delay Formula (Geometric Delay is not included).

Queue Model: HCM Queue Formula.

Gap-Acceptance Capacity: Traditional M1.

HV (%) values are calculated for All Movement Classes of All Heavy Vehicle Model Designation.

MOVEMENT SUMMARY

Site: 101 [2022 Existing PM Peak Hour (Site Folder: General)]

Givens Lane and Progress Street

Site Category: Existing Design
Roundabout

Vehicle Movement Performance														
Mov ID	Turn	INPUT VOLUMES		DEMAND FLOWS		Deg. Satn v/c	Aver. Delay sec	Level of Service	95% BACK OF QUEUE		Prop. Que	Effective Stop Rate	Aver. No. Cycles	Aver. Speed mph
		[Total veh/h	HV %	[Total veh/h	HV %				[Veh. veh	Dist] ft				
South: Progress Street														
9	L2	9	22.0	10	22.0	0.050	4.0	LOS A	0.2	5.2	0.23	0.10	0.23	25.0
6	T1	6	100.0	7	100.0	0.050	6.2	LOS A	0.2	5.2	0.23	0.10	0.23	24.5
31	R2	31	0.0	36	0.0	0.050	3.3	LOS A	0.2	5.2	0.23	0.10	0.23	23.9
Approach		46	17.3	53	17.3	0.050	3.8	LOS A	0.2	5.2	0.23	0.10	0.23	24.2
East: Givens Lane														
16	L2	16	0.0	18	0.0	0.096	3.5	LOS A	0.4	11.1	0.14	0.05	0.14	25.3
94	T1	94	0.0	108	0.0	0.096	3.5	LOS A	0.4	11.1	0.14	0.05	0.14	24.8
1	R2	1	0.0	1	0.0	0.096	3.5	LOS A	0.4	11.1	0.14	0.05	0.14	24.2
Approach		111	0.0	128	0.0	0.096	3.5	LOS A	0.4	11.1	0.14	0.05	0.14	24.9
North: Progress Street														
u	U	1	0.0	1	0.0	0.016	3.2	LOS A	0.1	1.6	0.27	0.12	0.27	25.6
2	L2	2	0.0	2	0.0	0.016	3.2	LOS A	0.1	1.6	0.27	0.12	0.27	24.9
4	T1	4	100.0	5	100.0	0.016	6.2	LOS A	0.1	1.6	0.27	0.12	0.27	24.4
6	R2	6	0.0	7	0.0	0.016	3.2	LOS A	0.1	1.6	0.27	0.12	0.27	23.8
Approach		13	30.8	15	30.8	0.016	4.1	LOS A	0.1	1.6	0.27	0.12	0.27	24.3
West: Givens Lane														
10	L2	10	10.0	11	10.0	0.084	3.6	LOS A	0.4	9.5	0.12	0.04	0.12	25.4
75	T1	75	0.0	86	0.0	0.084	3.4	LOS A	0.4	9.5	0.12	0.04	0.12	24.9
11	R2	11	9.0	13	9.0	0.084	3.6	LOS A	0.4	9.5	0.12	0.04	0.12	24.2
Approach		96	2.1	110	2.1	0.084	3.4	LOS A	0.4	9.5	0.12	0.04	0.12	24.9
All Vehicles		266	5.3	306	5.3	0.096	3.6	LOS A	0.4	11.1	0.16	0.06	0.16	24.7

Site Level of Service (LOS) Method: Delay & v/c (HCM 6). Site LOS Method is specified in the Parameter Settings dialog (Site tab).

Roundabout LOS Method: Same as Sign Control.

Vehicle movement LOS values are based on average delay and v/c ratio (degree of saturation) per movement.

LOS F will result if v/c > 1 irrespective of movement delay value (does not apply for approaches and intersection).

Intersection and Approach LOS values are based on average delay for all movements (v/c not used as specified in HCM 6).

Roundabout Capacity Model: US HCM 6.

Delay Model: HCM Delay Formula (Geometric Delay is not included).

Queue Model: HCM Queue Formula.

Gap-Acceptance Capacity: Traditional M1.

HV (%) values are calculated for All Movement Classes of All Heavy Vehicle Model Designation.

MOVEMENT SUMMARY

Site: 101 [2027 No-Build AM Peak Hour (Site Folder: General)]

Givens Lane and Progress Street

Site Category: Existing Design
Roundabout

Vehicle Movement Performance														
Mov ID	Turn	INPUT VOLUMES		DEMAND FLOWS		Deg. Satn v/c	Aver. Delay sec	Level of Service	95% BACK OF QUEUE		Prop. Que	Effective Stop Rate	Aver. No. Cycles	Aver. Speed mph
		[Total veh/h]	[HV %]	[Total veh/h]	[HV %]				[Veh. veh]	[Dist ft]				
South: Progress Street														
9	L2	3	33.0	3	33.0	0.024	3.8	LOS A	0.1	2.5	0.15	0.05	0.15	25.2
6	T1	3	67.0	3	67.0	0.024	4.8	LOS A	0.1	2.5	0.15	0.05	0.15	24.7
31	R2	18	0.0	21	0.0	0.024	2.9	LOS A	0.1	2.5	0.15	0.05	0.15	24.1
Approach		24	12.5	28	12.5	0.024	3.3	LOS A	0.1	2.5	0.15	0.05	0.15	24.3
East: Givens Lane														
16	L2	21	0.0	24	0.0	0.150	3.9	LOS A	0.7	18.5	0.10	0.03	0.10	25.3
94	T1	155	0.0	178	0.0	0.150	3.9	LOS A	0.7	18.5	0.10	0.03	0.10	24.7
1	R2	1	0.0	1	0.0	0.150	3.9	LOS A	0.7	18.5	0.10	0.03	0.10	24.1
Approach		177	0.0	203	0.0	0.150	3.9	LOS A	0.7	18.5	0.10	0.03	0.10	24.8
North: Progress Street														
u	U	1	0.0	1	0.0	0.038	3.6	LOS A	0.1	3.9	0.34	0.19	0.34	25.8
2	L2	1	0.0	1	0.0	0.038	3.6	LOS A	0.1	3.9	0.34	0.19	0.34	25.1
4	T1	12	45.0	14	45.0	0.038	5.0	LOS A	0.1	3.9	0.34	0.19	0.34	24.6
6	R2	18	0.0	21	0.0	0.038	3.6	LOS A	0.1	3.9	0.34	0.19	0.34	23.9
Approach		32	16.9	37	16.9	0.038	4.1	LOS A	0.1	3.9	0.34	0.19	0.34	24.3
West: Givens Lane														
10	L2	7	0.0	8	0.0	0.039	3.0	LOS A	0.2	4.2	0.15	0.05	0.15	25.4
75	T1	34	0.0	39	0.0	0.039	3.0	LOS A	0.2	4.2	0.15	0.05	0.15	24.9
11	R2	3	33.0	3	33.0	0.039	3.9	LOS A	0.2	4.2	0.15	0.05	0.15	24.2
Approach		44	2.3	51	2.3	0.039	3.1	LOS A	0.2	4.2	0.15	0.05	0.15	24.9
All Vehicles		277	3.4	318	3.4	0.150	3.7	LOS A	0.7	18.5	0.14	0.05	0.14	24.7

Site Level of Service (LOS) Method: Delay & v/c (HCM 6). Site LOS Method is specified in the Parameter Settings dialog (Site tab).
Roundabout LOS Method: Same as Sign Control.

Vehicle movement LOS values are based on average delay and v/c ratio (degree of saturation) per movement.

LOS F will result if v/c > 1 irrespective of movement delay value (does not apply for approaches and intersection).

Intersection and Approach LOS values are based on average delay for all movements (v/c not used as specified in HCM 6).

Roundabout Capacity Model: US HCM 6.

Delay Model: HCM Delay Formula (Geometric Delay is not included).

Queue Model: HCM Queue Formula.

Gap-Acceptance Capacity: Traditional M1.

HV (%) values are calculated for All Movement Classes of All Heavy Vehicle Model Designation.

MOVEMENT SUMMARY

Site: 101 [2027 No-Build PM Peak Hour (Site Folder: General)]

Givens Lane and Progress Street

Site Category: Existing Design
Roundabout

Vehicle Movement Performance														
Mov ID	Turn	INPUT VOLUMES		DEMAND FLOWS		Deg. Satn v/c	Aver. Delay sec	Level of Service	95% BACK OF QUEUE		Prop. Que	Effective Stop Rate	Aver. No. Cycles	Aver. Speed mph
		[Total veh/h]	[HV %]	[Total veh/h]	[HV %]				[Veh. veh]	[Dist ft]				
South: Progress Street														
9	L2	10	22.0	11	22.0	0.061	4.1	LOS A	0.2	6.4	0.25	0.12	0.25	25.0
6	T1	7	100.0	8	100.0	0.061	6.4	LOS A	0.2	6.4	0.25	0.12	0.25	24.5
31	R2	39	0.0	45	0.0	0.061	3.5	LOS A	0.2	6.4	0.25	0.12	0.25	23.9
Approach		56	16.4	64	16.4	0.061	4.0	LOS A	0.2	6.4	0.25	0.12	0.25	24.2
East: Givens Lane														
16	L2	22	0.0	25	0.0	0.116	3.7	LOS A	0.5	13.6	0.16	0.05	0.16	25.3
94	T1	110	0.0	126	0.0	0.116	3.7	LOS A	0.5	13.6	0.16	0.05	0.16	24.7
1	R2	1	0.0	1	0.0	0.116	3.7	LOS A	0.5	13.6	0.16	0.05	0.16	24.1
Approach		133	0.0	153	0.0	0.116	3.7	LOS A	0.5	13.6	0.16	0.05	0.16	24.8
North: Progress Street														
u	U	1	0.0	1	0.0	0.020	3.3	LOS A	0.1	1.9	0.29	0.14	0.29	25.6
2	L2	2	0.0	2	0.0	0.020	3.3	LOS A	0.1	1.9	0.29	0.14	0.29	24.9
4	T1	5	100.0	6	100.0	0.020	6.4	LOS A	0.1	1.9	0.29	0.14	0.29	24.4
6	R2	7	0.0	8	0.0	0.020	3.3	LOS A	0.1	1.9	0.29	0.14	0.29	23.8
Approach		15	33.3	17	33.3	0.020	4.3	LOS A	0.1	1.9	0.29	0.14	0.29	24.2
West: Givens Lane														
10	L2	11	10.0	13	10.0	0.099	3.8	LOS A	0.4	11.4	0.14	0.05	0.14	25.4
75	T1	89	0.0	102	0.0	0.099	3.5	LOS A	0.4	11.4	0.14	0.05	0.14	24.8
11	R2	12	9.0	14	9.0	0.099	3.8	LOS A	0.4	11.4	0.14	0.05	0.14	24.2
Approach		112	1.9	129	1.9	0.099	3.6	LOS A	0.4	11.4	0.14	0.05	0.14	24.8
All Vehicles		316	5.2	363	5.2	0.116	3.7	LOS A	0.5	13.6	0.18	0.07	0.18	24.7

Site Level of Service (LOS) Method: Delay & v/c (HCM 6). Site LOS Method is specified in the Parameter Settings dialog (Site tab).
Roundabout LOS Method: Same as Sign Control.

Vehicle movement LOS values are based on average delay and v/c ratio (degree of saturation) per movement.

LOS F will result if v/c > 1 irrespective of movement delay value (does not apply for approaches and intersection).

Intersection and Approach LOS values are based on average delay for all movements (v/c not used as specified in HCM 6).

Roundabout Capacity Model: US HCM 6.

Delay Model: HCM Delay Formula (Geometric Delay is not included).

Queue Model: HCM Queue Formula.

Gap-Acceptance Capacity: Traditional M1.

HV (%) values are calculated for All Movement Classes of All Heavy Vehicle Model Designation.

MOVEMENT SUMMARY

Site: 101 [2027 Build AM Peak Hour (Site Folder: General)]

Givens Lane and Progress Street

Site Category: Existing Design
Roundabout

Vehicle Movement Performance														
Mov ID	Turn	INPUT VOLUMES		DEMAND FLOWS		Deg. Satn	Aver. Delay	Level of Service	95% BACK OF QUEUE		Prop. Que	Effective Stop Rate	Aver. No. Cycles	Aver. Speed
		[Total veh/h]	[HV %]	[Total veh/h]	[HV %]				[Veh. veh]	[Dist ft]				
South: Progress Street														
9	L2	3	33.0	3	33.0	0.027	3.9	LOS A	0.1	2.8	0.16	0.05	0.16	25.2
6	T1	5	67.0	6	67.0	0.027	4.8	LOS A	0.1	2.8	0.16	0.05	0.16	24.7
31	R2	18	0.0	21	0.0	0.027	3.0	LOS A	0.1	2.8	0.16	0.05	0.16	24.1
Approach		26	16.7	30	16.7	0.027	3.4	LOS A	0.1	2.8	0.16	0.05	0.16	24.3
East: Givens Lane														
16	L2	21	0.0	24	0.0	0.153	3.9	LOS A	0.8	18.8	0.11	0.03	0.11	25.3
94	T1	157	0.0	180	0.0	0.153	3.9	LOS A	0.8	18.8	0.11	0.03	0.11	24.7
1	R2	1	0.0	1	0.0	0.153	3.9	LOS A	0.8	18.8	0.11	0.03	0.11	24.1
Approach		179	0.0	206	0.0	0.153	3.9	LOS A	0.8	18.8	0.11	0.03	0.11	24.8
North: Progress Street														
u	U	1	0.0	1	0.0	0.050	3.7	LOS A	0.2	5.1	0.34	0.20	0.34	25.7
2	L2	2	0.0	2	0.0	0.050	3.7	LOS A	0.2	5.1	0.34	0.20	0.34	25.0
4	T1	17	45.0	20	45.0	0.050	5.1	LOS A	0.2	5.1	0.34	0.20	0.34	24.5
6	R2	21	0.0	24	0.0	0.050	3.7	LOS A	0.2	5.1	0.34	0.20	0.34	23.9
Approach		41	18.7	47	18.7	0.050	4.3	LOS A	0.2	5.1	0.34	0.20	0.34	24.2
West: Givens Lane														
10	L2	8	0.0	9	0.0	0.041	3.1	LOS A	0.2	4.5	0.16	0.06	0.16	25.4
75	T1	35	0.0	40	0.0	0.041	3.1	LOS A	0.2	4.5	0.16	0.06	0.16	24.8
11	R2	3	33.0	3	33.0	0.041	4.0	LOS A	0.2	4.5	0.16	0.06	0.16	24.2
Approach		46	2.2	53	2.2	0.041	3.2	LOS A	0.2	4.5	0.16	0.06	0.16	24.9
All Vehicles		292	4.4	336	4.4	0.153	3.8	LOS A	0.8	18.8	0.16	0.06	0.16	24.7

Site Level of Service (LOS) Method: Delay & v/c (HCM 6). Site LOS Method is specified in the Parameter Settings dialog (Site tab).

Roundabout LOS Method: Same as Sign Control.

Vehicle movement LOS values are based on average delay and v/c ratio (degree of saturation) per movement.

LOS F will result if v/c > 1 irrespective of movement delay value (does not apply for approaches and intersection).

Intersection and Approach LOS values are based on average delay for all movements (v/c not used as specified in HCM 6).

Roundabout Capacity Model: US HCM 6.

Delay Model: HCM Delay Formula (Geometric Delay is not included).

Queue Model: HCM Queue Formula.

Gap-Acceptance Capacity: Traditional M1.

HV (%) values are calculated for All Movement Classes of All Heavy Vehicle Model Designation.

MOVEMENT SUMMARY

Site: 101 [2027 Build PM Peak Hour (Site Folder: General)]

Givens Lane and Progress Street

Site Category: Existing Design
Roundabout

Vehicle Movement Performance														
Mov ID	Turn	INPUT VOLUMES		DEMAND FLOWS		Deg. Satn	Aver. Delay	Level of Service	95% BACK OF QUEUE		Prop. Que	Effective Stop Rate	Aver. No. Cycles	Aver. Speed
		[Total veh/h]	[HV %]	[Total veh/h]	[HV %]				[Veh. veh]	[Dist ft]				
South: Progress Street														
9	L2	10	22.0	11	22.0	0.071	4.3	LOS A	0.3	7.4	0.26	0.13	0.26	24.9
6	T1	12	100.0	14	100.0	0.071	6.6	LOS A	0.3	7.4	0.26	0.13	0.26	24.4
31	R2	39	0.0	45	0.0	0.071	3.6	LOS A	0.3	7.4	0.26	0.13	0.26	23.8
Approach		61	23.3	70	23.3	0.071	4.3	LOS A	0.3	7.4	0.26	0.13	0.26	24.1
East: Givens Lane														
16	L2	22	0.0	25	0.0	0.120	3.8	LOS A	0.6	14.1	0.19	0.07	0.19	25.2
94	T1	111	0.0	128	0.0	0.120	3.8	LOS A	0.6	14.1	0.19	0.07	0.19	24.7
1	R2	3	0.0	3	0.0	0.120	3.8	LOS A	0.6	14.1	0.19	0.07	0.19	24.1
Approach		136	0.0	156	0.0	0.120	3.8	LOS A	0.6	14.1	0.19	0.07	0.19	24.8
North: Progress Street														
u	U	1	0.0	1	0.0	0.029	3.4	LOS A	0.1	2.8	0.30	0.15	0.30	25.5
2	L2	3	0.0	3	0.0	0.029	3.4	LOS A	0.1	2.8	0.30	0.15	0.30	24.8
4	T1	8	100.0	9	100.0	0.029	6.5	LOS A	0.1	2.8	0.30	0.15	0.30	24.3
6	R2	9	0.0	10	0.0	0.029	3.4	LOS A	0.1	2.8	0.30	0.15	0.30	23.7
Approach		21	38.1	24	38.1	0.029	4.5	LOS A	0.1	2.8	0.30	0.15	0.30	24.2
West: Givens Lane														
10	L2	14	10.0	16	10.0	0.105	3.9	LOS A	0.5	12.0	0.16	0.06	0.16	25.3
75	T1	91	0.0	105	0.0	0.105	3.6	LOS A	0.5	12.0	0.16	0.06	0.16	24.8
11	R2	12	9.0	14	9.0	0.105	3.8	LOS A	0.5	12.0	0.16	0.06	0.16	24.2
Approach		117	2.1	134	2.1	0.105	3.6	LOS A	0.5	12.0	0.16	0.06	0.16	24.8
All Vehicles		335	7.4	385	7.4	0.120	3.9	LOS A	0.6	14.1	0.20	0.08	0.20	24.6

Site Level of Service (LOS) Method: Delay & v/c (HCM 6). Site LOS Method is specified in the Parameter Settings dialog (Site tab).

Roundabout LOS Method: Same as Sign Control.

Vehicle movement LOS values are based on average delay and v/c ratio (degree of saturation) per movement.

LOS F will result if v/c > 1 irrespective of movement delay value (does not apply for approaches and intersection).

Intersection and Approach LOS values are based on average delay for all movements (v/c not used as specified in HCM 6).

Roundabout Capacity Model: US HCM 6.

Delay Model: HCM Delay Formula (Geometric Delay is not included).

Queue Model: HCM Queue Formula.

Gap-Acceptance Capacity: Traditional M1.

HV (%) values are calculated for All Movement Classes of All Heavy Vehicle Model Designation.

SIMTRAFFIC QUEUEING REPORTS

Intersection: 1: N Main Street & Countryside Court

Movement	EB	NB	SB
Directions Served	LR	LT	TR
Maximum Queue (ft)	51	52	19
Average Queue (ft)	16	4	1
95th Queue (ft)	42	26	8
Link Distance (ft)	982	395	1099
Upstream Blk Time (%)			
Queuing Penalty (veh)			
Storage Bay Dist (ft)			
Storage Blk Time (%)			
Queuing Penalty (veh)			

Intersection: 2: N Main Street & Givens Lane/Mountain Breeze Drive

Movement	EB	WB	NB	SB
Directions Served	LTR	LTR	LTR	LTR
Maximum Queue (ft)	56	52	78	48
Average Queue (ft)	22	20	9	6
95th Queue (ft)	49	47	40	28
Link Distance (ft)	2011	1207	1112	395
Upstream Blk Time (%)				
Queuing Penalty (veh)				
Storage Bay Dist (ft)				
Storage Blk Time (%)				
Queuing Penalty (veh)				

Intersection: 3: Givens Lane & Carroll Drive

Movement	EB	SB
Directions Served	LT	LR
Maximum Queue (ft)	31	61
Average Queue (ft)	2	32
95th Queue (ft)	14	54
Link Distance (ft)	1539	982
Upstream Blk Time (%)		
Queuing Penalty (veh)		
Storage Bay Dist (ft)		
Storage Blk Time (%)		
Queuing Penalty (veh)		

Intersection: 4: Progress Street & Givens Lane

Movement	EB	WB	NB	SB
Directions Served	LTR	LTR	LTR	ULTR
Maximum Queue (ft)	18	34	16	42
Average Queue (ft)	1	1	1	2
95th Queue (ft)	9	14	8	20
Link Distance (ft)	1040	1539	1026	966
Upstream Blk Time (%)				
Queuing Penalty (veh)				
Storage Bay Dist (ft)				
Storage Blk Time (%)				
Queuing Penalty (veh)				

Network Summary

Network wide Queuing Penalty: 0

Intersection: 1: N Main Street & Countryside Court

Movement	EB	NB
Directions Served	LR	LT
Maximum Queue (ft)	60	83
Average Queue (ft)	19	11
95th Queue (ft)	46	45
Link Distance (ft)	982	395
Upstream Blk Time (%)		
Queuing Penalty (veh)		
Storage Bay Dist (ft)		
Storage Blk Time (%)		
Queuing Penalty (veh)		

Intersection: 2: N Main Street & Givens Lane/Mountain Breeze Drive

Movement	EB	WB	NB	SB
Directions Served	LTR	LTR	LTR	LTR
Maximum Queue (ft)	62	55	95	56
Average Queue (ft)	27	23	9	7
95th Queue (ft)	56	49	60	33
Link Distance (ft)	2011	1207	1112	395
Upstream Blk Time (%)				
Queuing Penalty (veh)				
Storage Bay Dist (ft)				
Storage Blk Time (%)				
Queuing Penalty (veh)				

Intersection: 3: Givens Lane & Carroll Drive

Movement	EB	WB	SB
Directions Served	LT	TR	LR
Maximum Queue (ft)	44	6	38
Average Queue (ft)	4	0	22
95th Queue (ft)	24	4	45
Link Distance (ft)	1539	2011	982
Upstream Blk Time (%)			
Queuing Penalty (veh)			
Storage Bay Dist (ft)			
Storage Blk Time (%)			
Queuing Penalty (veh)			

Intersection: 4: Progress Street & Givens Lane

Movement	EB	WB	NB	SB
Directions Served	LTR	LTR	LTR	LTR
Maximum Queue (ft)	25	25	36	44
Average Queue (ft)	2	2	3	2
95th Queue (ft)	13	14	20	17
Link Distance (ft)	1040	1539	1026	966
Upstream Blk Time (%)				
Queuing Penalty (veh)				
Storage Bay Dist (ft)				
Storage Blk Time (%)				
Queuing Penalty (veh)				

Network Summary

Network wide Queuing Penalty: 0

Intersection: 1: N Main Street & Countryside Court

Movement	EB	NB
Directions Served	LR	LT
Maximum Queue (ft)	49	52
Average Queue (ft)	15	4
95th Queue (ft)	41	25
Link Distance (ft)	982	395
Upstream Blk Time (%)		
Queuing Penalty (veh)		
Storage Bay Dist (ft)		
Storage Blk Time (%)		
Queuing Penalty (veh)		

Intersection: 2: N Main Street & Givens Lane/Mountain Breeze Drive

Movement	EB	WB	NB	SB
Directions Served	LTR	LTR	LTR	LTR
Maximum Queue (ft)	57	59	84	66
Average Queue (ft)	21	23	15	8
95th Queue (ft)	49	49	55	36
Link Distance (ft)	2011	1207	1112	395
Upstream Blk Time (%)				
Queuing Penalty (veh)				
Storage Bay Dist (ft)				
Storage Blk Time (%)				
Queuing Penalty (veh)				

Intersection: 3: Givens Lane & Carroll Drive

Movement	EB	SB
Directions Served	LT	LR
Maximum Queue (ft)	35	64
Average Queue (ft)	3	31
95th Queue (ft)	19	54
Link Distance (ft)	1539	982
Upstream Blk Time (%)		
Queuing Penalty (veh)		
Storage Bay Dist (ft)		
Storage Blk Time (%)		
Queuing Penalty (veh)		

Intersection: 4: Progress Street & Givens Lane

Movement	EB	WB	NB	SB
Directions Served	LTR	LTR	LTR	ULTR
Maximum Queue (ft)	12	39	12	30
Average Queue (ft)	1	3	0	3
95th Queue (ft)	8	20	6	19
Link Distance (ft)	1040	1539	1026	966
Upstream Blk Time (%)				
Queuing Penalty (veh)				
Storage Bay Dist (ft)				
Storage Blk Time (%)				
Queuing Penalty (veh)				

Network Summary

Network wide Queuing Penalty: 0

Intersection: 1: N Main Street & Countryside Court

Movement	EB	NB
Directions Served	LR	LT
Maximum Queue (ft)	58	91
Average Queue (ft)	19	15
95th Queue (ft)	49	57
Link Distance (ft)	982	395
Upstream Blk Time (%)		
Queuing Penalty (veh)		
Storage Bay Dist (ft)		
Storage Blk Time (%)		
Queuing Penalty (veh)		

Intersection: 2: N Main Street & Givens Lane/Mountain Breeze Drive

Movement	EB	WB	NB	SB
Directions Served	LTR	LTR	LTR	LTR
Maximum Queue (ft)	69	74	147	61
Average Queue (ft)	29	26	21	6
95th Queue (ft)	61	58	88	32
Link Distance (ft)	2011	1207	1112	395
Upstream Blk Time (%)				
Queuing Penalty (veh)				
Storage Bay Dist (ft)				
Storage Blk Time (%)				
Queuing Penalty (veh)				

Intersection: 3: Givens Lane & Carroll Drive

Movement	EB	SB
Directions Served	LT	LR
Maximum Queue (ft)	41	51
Average Queue (ft)	7	23
95th Queue (ft)	30	49
Link Distance (ft)	1539	982
Upstream Blk Time (%)		
Queuing Penalty (veh)		
Storage Bay Dist (ft)		
Storage Blk Time (%)		
Queuing Penalty (veh)		

Intersection: 4: Progress Street & Givens Lane

Movement	EB	WB	NB	SB
Directions Served	LTR	LTR	LTR	LTR
Maximum Queue (ft)	24	39	32	35
Average Queue (ft)	1	4	2	2
95th Queue (ft)	12	24	15	16
Link Distance (ft)	1040	1539	1026	966
Upstream Blk Time (%)				
Queuing Penalty (veh)				
Storage Bay Dist (ft)				
Storage Blk Time (%)				
Queuing Penalty (veh)				

Network Summary

Network wide Queuing Penalty: 0

Intersection: 1: N Main Street & Countryside Court

Movement	EB	NB	SB
Directions Served	LR	LT	TR
Maximum Queue (ft)	62	92	12
Average Queue (ft)	22	7	0
95th Queue (ft)	51	42	6
Link Distance (ft)	982	395	1099
Upstream Blk Time (%)			
Queuing Penalty (veh)			
Storage Bay Dist (ft)			
Storage Blk Time (%)			
Queuing Penalty (veh)			

Intersection: 2: N Main Street & Givens Lane/Mountain Breeze Drive

Movement	EB	WB	NB	SB
Directions Served	LTR	LTR	LTR	LTR
Maximum Queue (ft)	59	64	90	62
Average Queue (ft)	24	26	16	9
95th Queue (ft)	52	54	58	38
Link Distance (ft)	2011	1207	1112	395
Upstream Blk Time (%)				
Queuing Penalty (veh)				
Storage Bay Dist (ft)				
Storage Blk Time (%)				
Queuing Penalty (veh)				

Intersection: 3: Givens Lane & Carroll Drive

Movement	EB	SB
Directions Served	LT	LR
Maximum Queue (ft)	31	60
Average Queue (ft)	2	33
95th Queue (ft)	15	56
Link Distance (ft)	1539	982
Upstream Blk Time (%)		
Queuing Penalty (veh)		
Storage Bay Dist (ft)		
Storage Blk Time (%)		
Queuing Penalty (veh)		

Intersection: 4: Progress Street & Givens Lane

Movement	EB	WB	NB	SB
Directions Served	LTR	LTR	LTR	ULTR
Maximum Queue (ft)	12	23	18	44
Average Queue (ft)	1	2	1	3
95th Queue (ft)	8	14	8	22
Link Distance (ft)	1040	1539	1026	966
Upstream Blk Time (%)				
Queuing Penalty (veh)				
Storage Bay Dist (ft)				
Storage Blk Time (%)				
Queuing Penalty (veh)				

Network Summary

Network wide Queuing Penalty: 0

Intersection: 1: N Main Street & Countryside Court

Movement	EB	NB	SB
Directions Served	LR	LT	TR
Maximum Queue (ft)	63	76	12
Average Queue (ft)	24	14	0
95th Queue (ft)	55	53	6
Link Distance (ft)	982	395	1099
Upstream Blk Time (%)			
Queuing Penalty (veh)			
Storage Bay Dist (ft)			
Storage Blk Time (%)			
Queuing Penalty (veh)			

Intersection: 2: N Main Street & Givens Lane/Mountain Breeze Drive

Movement	EB	WB	NB	SB
Directions Served	LTR	LTR	LTR	LTR
Maximum Queue (ft)	74	72	172	94
Average Queue (ft)	30	27	29	11
95th Queue (ft)	65	58	103	51
Link Distance (ft)	2011	1207	1112	395
Upstream Blk Time (%)				
Queuing Penalty (veh)				
Storage Bay Dist (ft)				
Storage Blk Time (%)				
Queuing Penalty (veh)				

Intersection: 3: Givens Lane & Carroll Drive

Movement	EB	WB	SB
Directions Served	LT	TR	LR
Maximum Queue (ft)	49	6	61
Average Queue (ft)	7	0	25
95th Queue (ft)	31	4	51
Link Distance (ft)	1539	2011	982
Upstream Blk Time (%)			
Queuing Penalty (veh)			
Storage Bay Dist (ft)			
Storage Blk Time (%)			
Queuing Penalty (veh)			

Intersection: 4: Progress Street & Givens Lane

Movement	EB	WB	NB	SB
Directions Served	LTR	LTR	LTR	LTR
Maximum Queue (ft)	40	40	54	57
Average Queue (ft)	4	4	4	4
95th Queue (ft)	24	22	27	26
Link Distance (ft)	1040	1539	1026	966
Upstream Blk Time (%)				
Queuing Penalty (veh)				
Storage Bay Dist (ft)				
Storage Blk Time (%)				
Queuing Penalty (veh)				

Network Summary

Network wide Queuing Penalty: 0